



Power Door Products

(914) 698-5083

www.PowerDoorProducts.com



MAGNA Q

**BARRIER ARM
OPERATOR
MANUAL**



MAGNA Q

BARRIER ARM OPERATOR



Reduces Costs Enhances Safety Minimizes Downtime & Repairs

**UL325
COMPLIANT**

EACH INCLUDE: ARM ATTACHMENT 15' ARM DISABLE SENSOR



The widest selection of **AC & DC Gate Operators** for all your residential and commercial installations.

SLIDERS | SWINGERS | OVERHEADS | BARRIER ARM OPERATORS

allomatic.net

TABLE OF CONTENTS

SAFETY AND INTRODUCTION

- Safety Instructions 1–2
- UL 325 Class Types 3
- Operator Specifications 4

INSTALLATION

- Operator Dimensions & Concrete Pad 5
- Arm Opening Direction & Travel Adjustment 6
- Arm Attachment Bracket Installation 7
- Arm Disable Sensor Installation 8
- Loop Layout & Operational Configurations 9–12
- AMS (Access Management System) Setup 13
- LED Strip & Edge Sensor Installation 14
- AC Power Electrical Wiring Connections 15

BOARD FEATURES

- DIP-Switch Functions 16
- Auto Close Timer & Receiver Wiring 17
- Arm Force Adjustment 18
- Primary/Secondary Setup & Wiring 19
- Auxiliary Relay & Leaf Delay Setting 20

ACCESSORY INSTALLATION

- Entrapment Protection Installation 21–23
- Accessory Wiring 24–25
- Solar Panel Wiring 26–27
- LED Diagnostics 28
- Technical Troubleshooting 29
- AUX Inputs Programming 30
- LCD Display Settings & Diagnostics 31–32

MANUAL RELEASE INSTRUCTIONS

- Manual Operation 33

ACCESSORIES & PARTS BREAKDOWN

- Blowout Drawing See Website

WARRANTY AND CUSTOMER RECORD

- Warranty & Customer Record 34–35

IMPORTANT SAFETY INSTRUCTIONS

WARNING

TO REDUCE THE RISK OF **INJURY**:

READ AND FOLLOW ALL INSTALLATION INSTRUCTIONS. DO NOT START INSTALLATION UNTIL YOU HAVE READ AND UNDERSTOOD THESE DIRECTIONS. IF THERE IS SOMETHING YOU DO NOT UNDERSTAND, PLEASE CALL US.

NEVER let children operate or play with gate controls.

Locate the control station and make sure it is (a) within sight of the gate and (b) at a minimum height of 5 feet so small children cannot reach it.

Install the enclosed entrapment warning signs next to the control station and in a prominent location.

For operators equipped with a manual release, instruct the end user on the correct operation of the manual release. Use the manual release only when the gate is not moving. It is advised to turn off the power.

Always keep people and objects away from the gate. No one should cross the path of a moving gate.

The gate operator must be tested monthly. The gate must reverse on contact with a rigid object, or stop when an object activates the non-contact sensor(s). Always re-test the operator after adjusting the limits and/or force. Failure to adjust and re-test the gate operator properly may cause severe injury or death.

Keep gate(s) properly maintained. Have a qualified service technician make repairs to gate hardware and make proper adjustments to gate operator.

This gate entrance/exit is for vehicles only. Pedestrians must use a separate entrance.

There is nothing on a gate operator that can be easily repaired or adjusted without a great deal of experience. Call a qualified gate service technician who knows your gate operator.

SAVE THESE INSTRUCTIONS

IMPORTANT SAFETY INSTRUCTIONS (CONTINUED)

INSTALL THE GATE OPERATOR ONLY AFTER YOU HAVE READ THE FOLLOWING

BEFORE GATE OPERATOR INSTALLATION

- Confirm that the gate operator being installed is appropriate for the application.
- Confirm that the gate is designed and built to current published industry standards.
- Confirm that all appropriate safety features and safety accessory devices are being installed, including all entrapment protection devices.
- Make sure that the gate opens and closes freely (by hand) before installing the operator.
- Repair or replace worn or damaged gate hardware before installing the gate operator.
- Eliminate all gaps in the sliding gate below 6 feet that allow a 2 1/4" sphere to pass through any location. This includes the area of the adjacent fence covered when the gate is in the open position
- Eliminate all gaps in a swing gate below a 4 foot height that permits a 4" sphere to pass through any location. This includes the hinge area of the gate.

- Install a proper electrical ground to the gate operator.
- Controls intended for user activation must be located at least 6 feet away from any moving part of the gate, and where the user is prevented from reaching over, under, around, or through the gate to operate the controls.
- Outdoor or easily accessible controls shall have a security feature to prevent unauthorized use.
- The stop and/or reset button must be located in the line of sight of the gate. Activation of the operator reset control shall not cause the operator to move.
- Install a minimum of 2 warning signs, one on each side of the gate where they are easily visible.
- Take pictures of the installation.
- Test all safety features for proper function before placing the automatic vehicular gate in operation.

GATE OPERATOR INSTALLATION

- Operator must be disconnected from the power source before attempting any installation of accessories.
- Install gate operator according to the installation instructions in this manual.
- Adjust the operator clutch or load sensing device to the minimum force setting that will allow for reliable gate operation.
- Install the operator inside the fence line. Do not install the operator on the public side of the fence line.

MAINTENANCE

- Train owners/users on the basic functions and safety features of the gate system, including how to turn off the power and operate the manual disconnect feature.
- Leave safety instructions, product literature, installation manual, and maintenance manual with the owner or end user.
- Explain to the owner or end user the importance of routine service and operator testing on a monthly basis.

UL 325 CLASS TYPES AND OBSTRUCTION SENSING SYSTEMS

Each class must have (2) monitored entrapment protection devices in each entrapment zone to sense and react to obstructions within 2 seconds.

All-O-Matic's gate operators conform to the most rigid Class One.

UL 325 CLASS TYPES

CLASS ONE: RESIDENTIAL

- A vehicular gate operator intended for use in garages or parking areas associated with a residence of one to four single families.

CLASS TWO: COMMERCIAL OR GENERAL PUBLIC ACCESS

- A vehicular gate operator intended for use at a commercial location or building, such as a multi-family housing unit (five or more single family units), hotel, garages, retail stores, or other buildings accessible by or servicing the general public.

CLASS THREE: INDUSTRIAL OR LIMITED ACCESS

- A vehicular gate operator intended for use at an industrial location or building, such as a factory, loading dock area, or other locations not accessible by or intended to service the general public.

CLASS FOUR: RESTRICTED ACCESS

- A vehicular gate operator intended for use at a guarded industrial location or building, such as airport security areas or other restricted access locations not servicing the general public and where unauthorized access is prevented via supervision by security personnel.

THE SIX TYPES OF OBSTRUCTION SENSING SYSTEMS

TYPE A:

- Inherent entrapment protection system. This system must sense and initiate the reverse of the gate within 2 seconds of contact with a solid object.

TYPE B1:

- Non-contact sensor (photoelectric sensor or equivalent). This system shall, upon sensing an obstruction in the direction of the gate travel, reverse the gate within a maximum of 2 seconds.

TYPE B2:

- Contact sensor (edge device or equivalent). This system shall, upon sensing an obstruction in the direction of the gate travel, initiate the reversal of the gate within a maximum of 2 seconds.

TYPE C:

- Inherent force limiting, inherent adjustable clutch, or pressure relief valve.

TYPE D:

- Actuating device requiring continuous pressure to maintain opening or closing motion of the gate.

OPERATOR SPECIFICATIONS

	MAGNA Q 19	MAGNA Q 26
Standard Arm Length	15'-7"	26'
Arm Extension Option	4'-1" (for 19'-8" max length)	N/A
Warranty	10 year aluminum cabinet 3 years electrical and mechanical parts	10 years aluminum cabinet 3 years electrical and mechanical parts
Motor	24 VDC brushless with integrated gearbox	24 VDC brushless with integrated gearbox
Gate Speed	2.5 to 4.5 seconds per 90° (varies depending on arm length)	4.5 to 8 seconds per 90° (varies depending on arm length)
Power Options	115 VAC 50/60Hz, single phase - 4 amps 230 VAC 50/60Hz, single phase - 2 amp 24 VDC solar panel - up to 80 watts	115 VAC 50/60Hz single phase - 4.5 amps 230 VAC 50/60Hz single phase - 2.5 amps 24 VDC solar panel up to 80 watts
Duty Cycle	Continuous	Continuous
Temperature Range	-20° to 150°	-20° to 150°
Gearbox Type	Helical Bevel and Spur Gear	Helical Bevel and Spur Gear
Width X Length X Height	11" W X 14" L X 42" H	11" W X 14" L X 42" H
Shipping Weight	120 lbs.	125 lbs.
Manual Release	Crank Spindle	Crank Spindle
Battery Backup	Two 7Ahr Batteries	Two 7Ahr Batteries
Arm Protection	Breakaway Standard	41B22X7/8
Breaker Requirement	20 amp dedicated	20 amp dedicated
UL Classes	II, III & IV	II, III & IV

OPERATOR DIMENSIONS AND CONCRETE PAD

Concrete Pad Installation Guidelines

1. Verify Local Codes

Check with local building authorities to determine required depth for the concrete pad.

2. Pad Height

Ensure the top of the concrete pad is **4 inches above ground level**.

3. Anchoring the Operator

Use **four (4) 3" anchor bolts** to securely fasten the operator to the concrete pad.

4. Conduit Placement

Route all conduits to the **center of the pad**. Refer to the dimensions below for the available area.

5. Operator Orientation

Mount the operator so the arm faces the direction of lane traffic flow.

(See the illustration at the bottom left of this page for reference.)

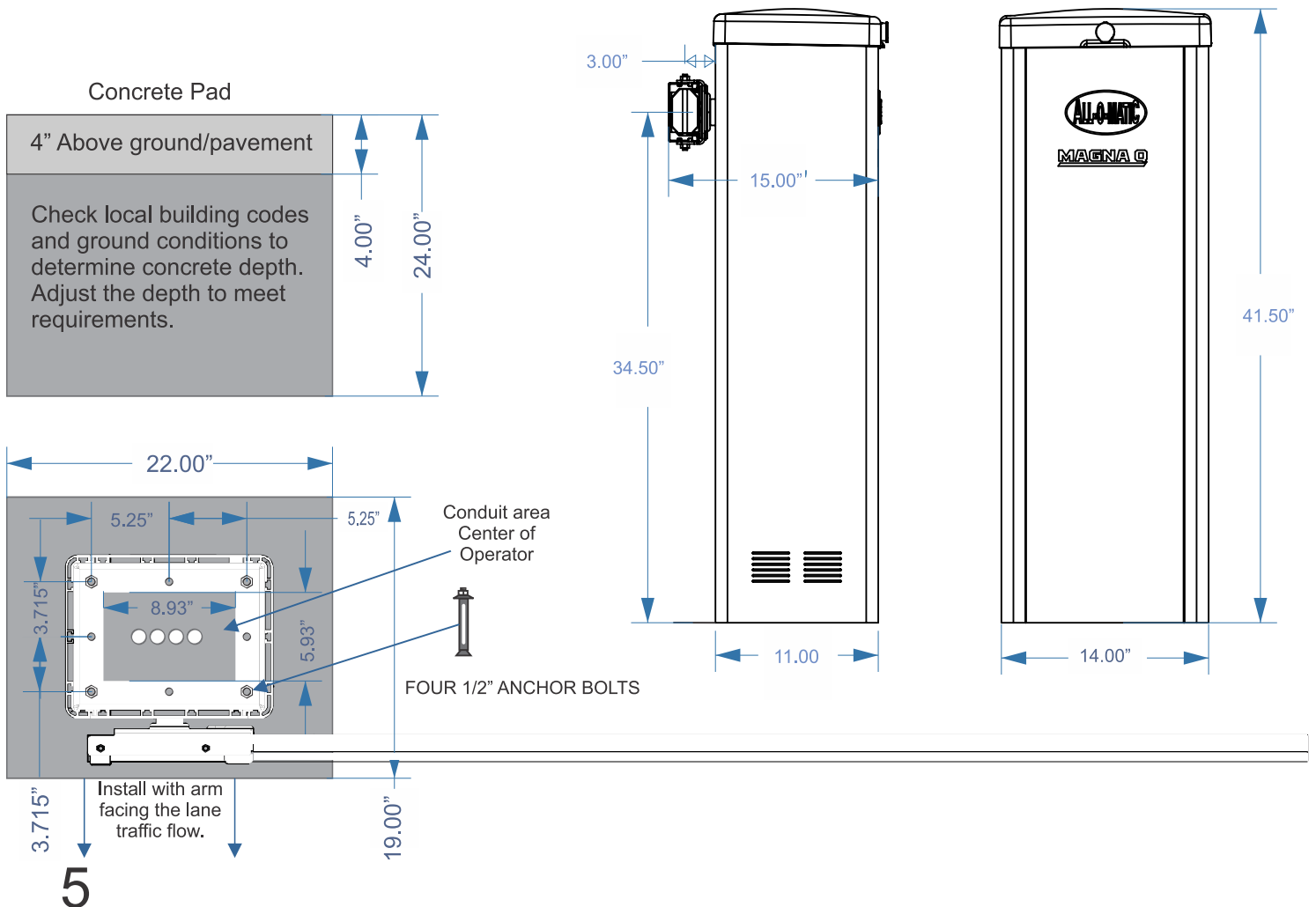

ARM OPENING DIRECTION AND TRAVEL ADJUSTMENT

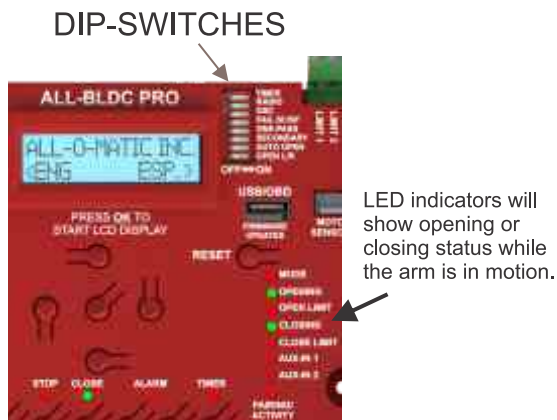

Setting the Barrier Arm Opening Direction

Use the **OPEN L/R dip switch (#8)** to configure the barrier arm operator's opening direction.

Determining Opening Direction:

- The opening direction is determined from the perspective of **standing behind the barrier operator and facing the control board**.
- **Indicator LEDs** on the control board will show the gate's movement direction during operation.

Dip Switch Settings:

- **OPEN L/R Switch OFF** → Left-hand opening
- **OPEN L/R Switch ON** → Right-hand opening

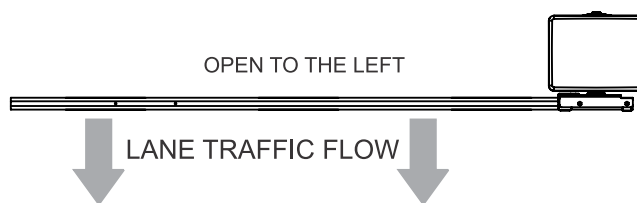

Limit Switch Adjustment Instructions

To Adjust the Limit Switches:

1. **Turn off** power to the operator.
2. Use a screwdriver to **loosen the limit cam**.
3. Adjust the limit cam as follows:
 - Rotate **toward** the limit switch to **decrease** travel.
 - Rotate **away** from the limit switch to **increase** travel.
4. **Re-secure the limit cam** by tightening screw.
5. **Restore power** to the operator.
6. Run the gate operator through a full open and close cycle.
 - If additional adjustments are needed, repeat steps 1–5.
7. Once the limits are correctly set, cycle the arm to the fully **closed position**.

Final Step – Learn Slow Down:

- Press and release the **“RESET”** button on the circuit board.
- Run the arm through **one uninterrupted cycle** (full open and full close) to calibrate the slow down function.

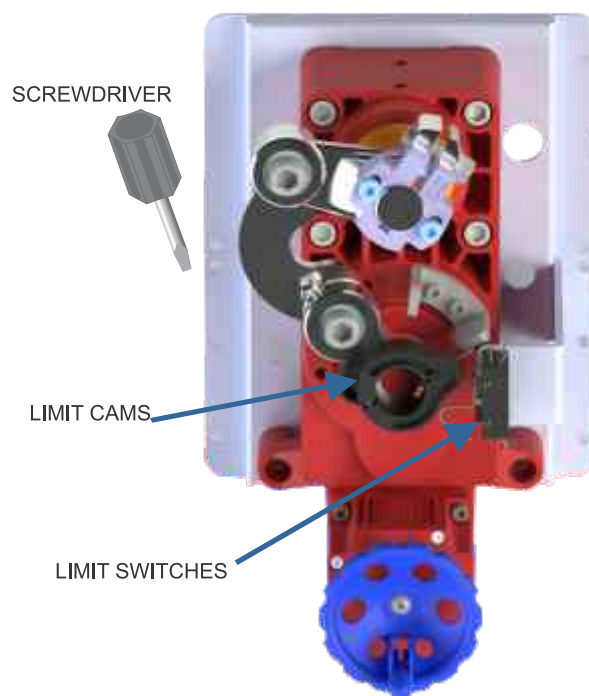

ARM ATTACHMENT BRACKET INSTALLATION

ARM ATTACHMENT BRACKET INSTALLATION PROCEDURE:

1. Set the direction in which the arm will open. Refer to the "ARM Opening Direction" page for dip-switch configurations that control motor direction.
2. After setting the dip-switch, power cycle the board to bring the motor to the CLOSE limit position." Confirm that the CLOSE-LIMIT LED is ON. Also, verify that the operator shaft rotates properly when running in both the OPEN and CLOSE directions.
3. Align the arm attachment bracket with the motor shaft. Position the bracket so the breakaway clip inserts face the traffic lane, and ensure the bracket top is level or close to level.. (It does not need to be perfectly level, as final adjustments can be made later via motor calibration.)
4. Align the washer flange with the holes in the arm attachment bracket. Use eight (8) socket head bolts to attach the bracket to the motor shaft, and tighten all bolts securely. Finally, install the hex bolt in the motor shaft center and fully tighten it."

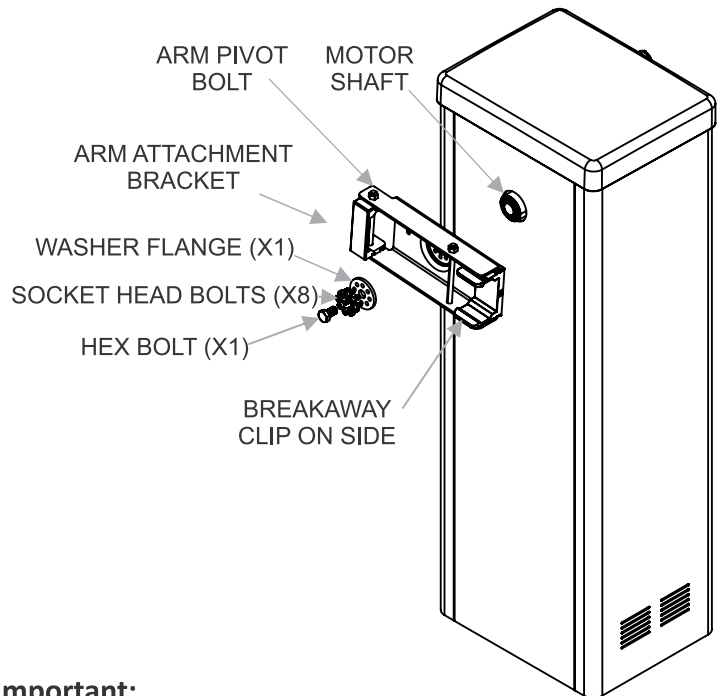

Important:

It is critical that the arm attachment bracket is installed in the correct direction.

If the bracket is mounted backwards or reversed, the breakaway function will not operate properly, which can lead to equipment damage or safety issues.

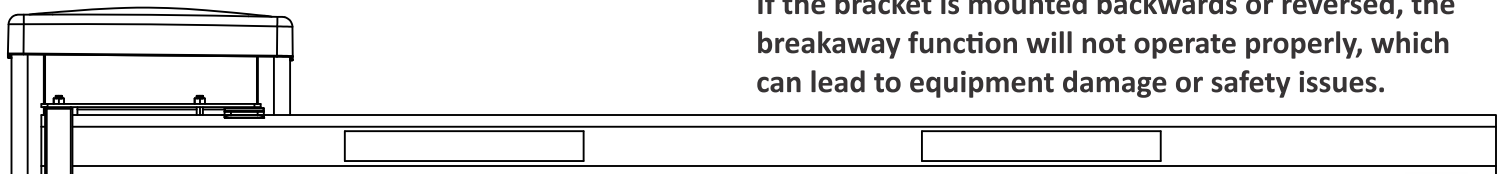

LEVELING ARM PROCEDURE

After the arm attachment bracket has been installed, mount the arm. Follow these steps to level the arm while it is in the lowered position and the board's CLOSE-LIMIT LED is ON:

1. Loosen the four (4) anti-slip set screws, followed by the anti-slip bolts.
2. If the output shaft clamp bolt is not already loose, loosen it as well.
3. Manually position the arm so it is level, and hold it in that position.
4. While keeping the arm level, tighten the anti-slip bolts first, then the anti-slip set screws.
5. Finally, tighten the output shaft clamp bolt to secure the shaft and maintain the arm's level position.

NOTE: Hand-tighten the anti-slip set screws only - do not apply torque.

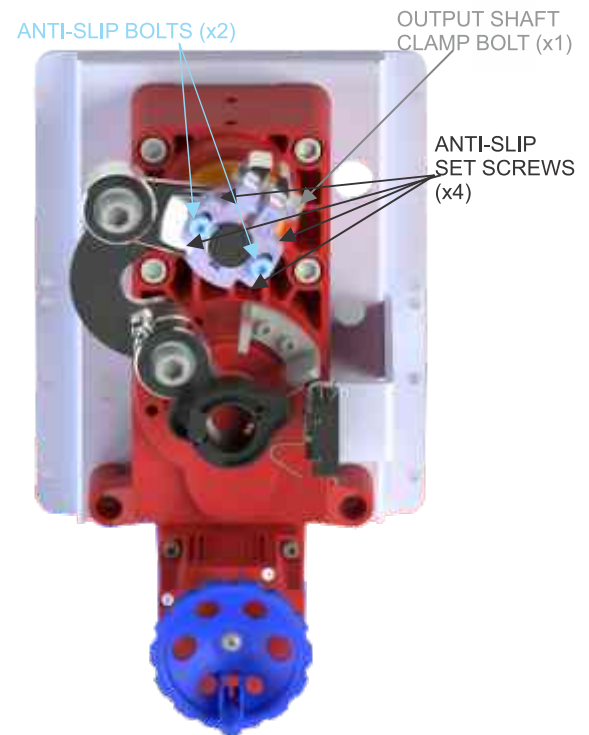

ARM DISABLE SENSOR INSTALLATION

Arm Disable Sensor Installation

Follow these steps to properly install the **Arm Disable Sensor** once the arm attachment bracket has been mounted to the motor shaft in the correct opening direction:

1. Mount the Sensor

- Align the sensor's mounting holes with the pre-drilled holes on the **bottom side** of the arm mounting bracket.
- Ensure the sensor is positioned **inside** the bracket, with the **wire harness facing toward the pivot bolt**.
(See illustration below for reference.)

2. Secure the Sensor

- Use the provided sensor mounting hardware (**square nuts, split lock washers, and screws**) to firmly secure the sensor to the bracket.

3. Route the Wire Harness

- Route the sensor's wire harness **toward the pivot bolt**, then back into the operator cabinet through the **pre-installed grommet**.
- **Important:** Use the grommet located on the **back side**, closest to the arm pivot bolt.

4. Connect to the Board

- Inside the operator cabinet, continue routing the wire harness to the **board terminal block** at the **bottom left corner** of the board.
- Make the following wire connections:
 - **Black wire** → Connect to the **COMMON** terminal (located below the FP_DISABLE screw).
 - **Red wire** → Connect directly to the **FP_DISABLE** terminal screw.

5. Verify Sensor Alignment and Operation

- Ensure the **magnet** mounted at the bottom of the arm **aligns properly** with the sensor.
- Verify that when the arm is in its normal (secured) position:
 - The **FP_DISABLE LED** on the board **turns off**, indicating correct sensor operation.

Notes:

- Secure all wiring neatly to prevent interference with moving parts.

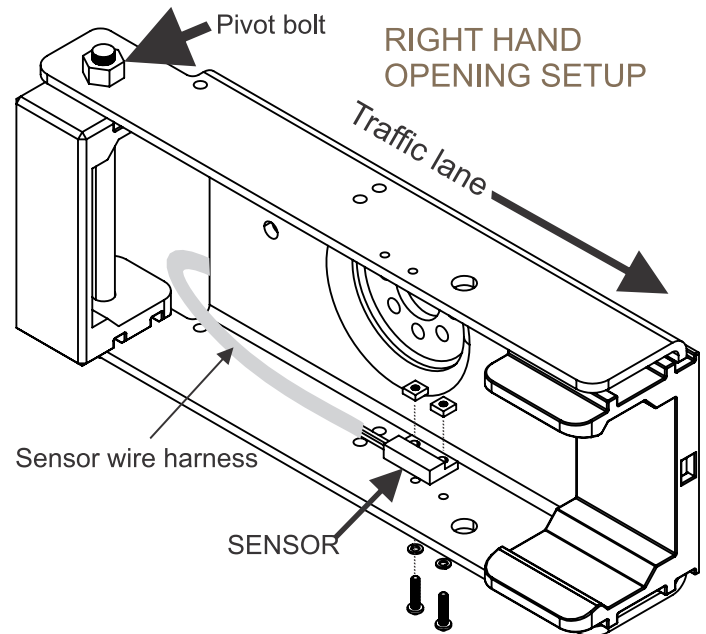
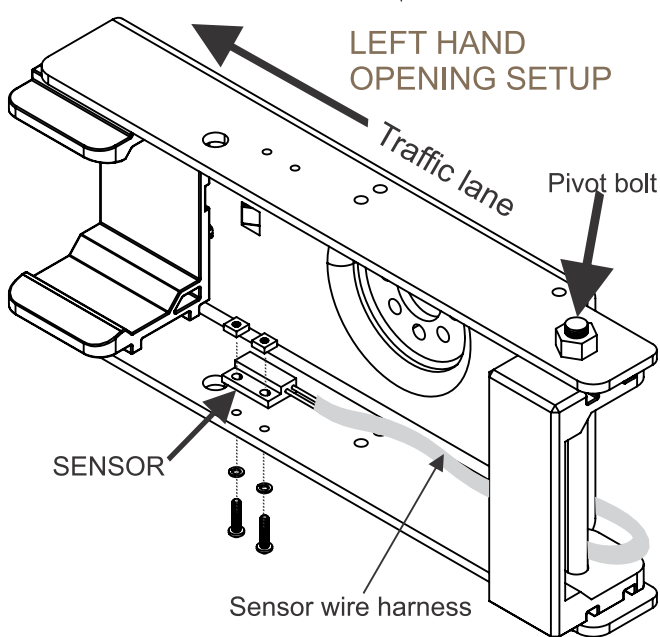

Important:

It is critical that the arm attachment bracket is installed in the correct direction.

If the bracket is mounted backwards or reversed, the breakaway function will not operate properly, which can lead to equipment damage or safety issues.

ENTRY LANE ONLY LOOP LAYOUT

Entry Lane Only — Wiring and Board Configuration

1. Down Loop (Safety Loop) Setup

- Install a **PRIME-VD1** plug-in loop detector in the **Safety Loop** slot of the **LPR-2** rack.
- **Safety Input Modes:**
The safety input can operate in two ways:
 - Down Loop Only Function (see note)**
 - Turn the **ONE-PASS** dip-switch **ON** and **OSC OFF**.
 - Down and Safety/Reverse Function**
 - Turn the **OSC** dip-switch **ON** & **ONE-PASS OFF**.
 - Safety/Reverse only Function**
 - Turn the **OSC** & **ONE-PASS** dip-switches **OFF**.
 - **Auto close timer** setup is required for this option.
- **Detector Setting:**
On the PRIME-VD1 detector, set **SW3** to the **ON** position.
(This configures the output as **Normally Closed (N.C.)**.)

2. Access Control Device Wiring

- Connect the access control device to the **COMMON** and **OPEN** terminal screws on the control board.

3. (Optional) Arming Loop Setup

- To use an arming loop with the access control device:
 - Install a **PRIME-VD1** plug-in loop detector in the **Phantom Loop** slot

of the **LPR-2** rack.

b. On the PRIME-VD1 detector, set **SW3** to the **OFF** position.
(This configures the output as **Normally Open (N.O.)**.)

c. Enable the Arming Loop:

- Access the **LCD Settings Menu**.
- Find and **enable** the **ARMING** loop setting.
- See LCD display instructions page for more details.

Note:

Once enabled, the control board will only initiate an open cycle if a command from the access control device is received **while a vehicle is detected** by the arming loop. If no vehicle is detected, access control commands will be ignored.

NOTE: When Down Loop is configured as Down Loop only, a Down Loop activation while arm is traveling down, will not interrupt the down/close cycle. The arm will continue to complete the down/close cycle.

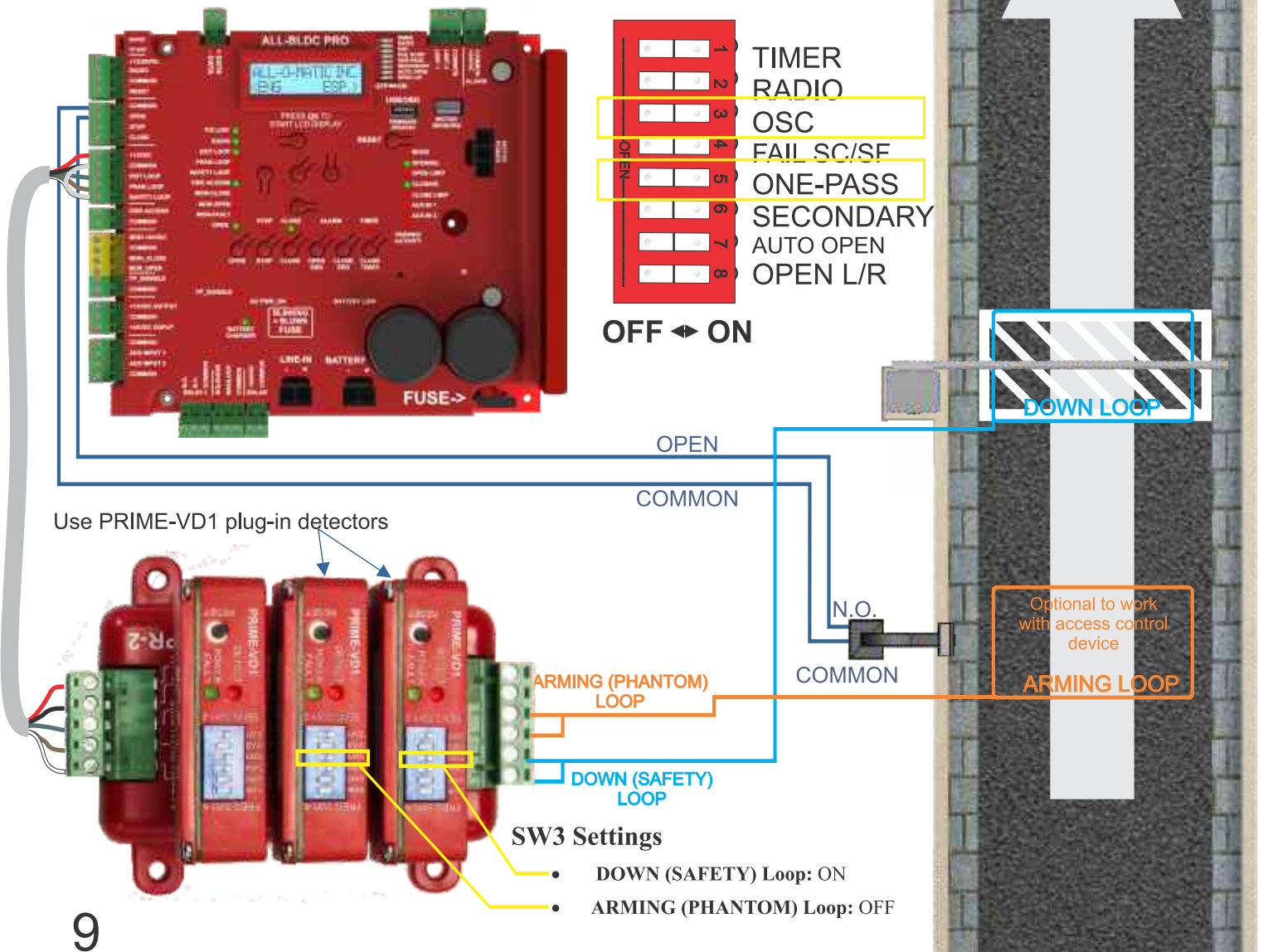

EXIT LANE ONLY LOOP LAYOUT

EXIT Lane Only — Wiring and Board Configuration

1. Down Loop (Safety Loop) Setup

- Install a **PRIME-VD1** plug-in loop detector in the **Safety Loop** slot of the **LPR-2** rack.
- Safety Input Modes:**
The safety input can operate in two ways:
 - Down Loop Only Function (see note)**
 - Turn the **ONE-PASS** dip-switch **ON** & **OSC** **OFF**.
 - Down and Safety/Reverse Function**
 - Turn the **OSC** dip-switch **ON** & **ONE-PASS** **OFF**.
 - Safety/Reverse Only Function**
 - Turn the **OSC** & **ONE-PASS** dip-switches **OFF**.
 - Auto close timer** setup is required for this option.

Detector Setting:

On the **PRIME-VD1** detector, set **SW3** to the **ON** position.

(This configures the output as **Normally Closed (N.C.)**.)

2. Exit Loop Setup

- Install a **PRIME-VD1** plug-in loop detector in the **EXIT Loop** slot of the **LPR-2** rack.
- Detector Setting:**
On the **PRIME-VD1** detector, set **SW3** to the **OFF** position.
(This configures the output as **Normally Open (N.O.)**)

NOTE: When Down Loop is configured for Down Loop only, a Down Loop activation while arm is traveling down, will not interrupt the down/close cycle. The arm will continue to complete the down/close cycle.

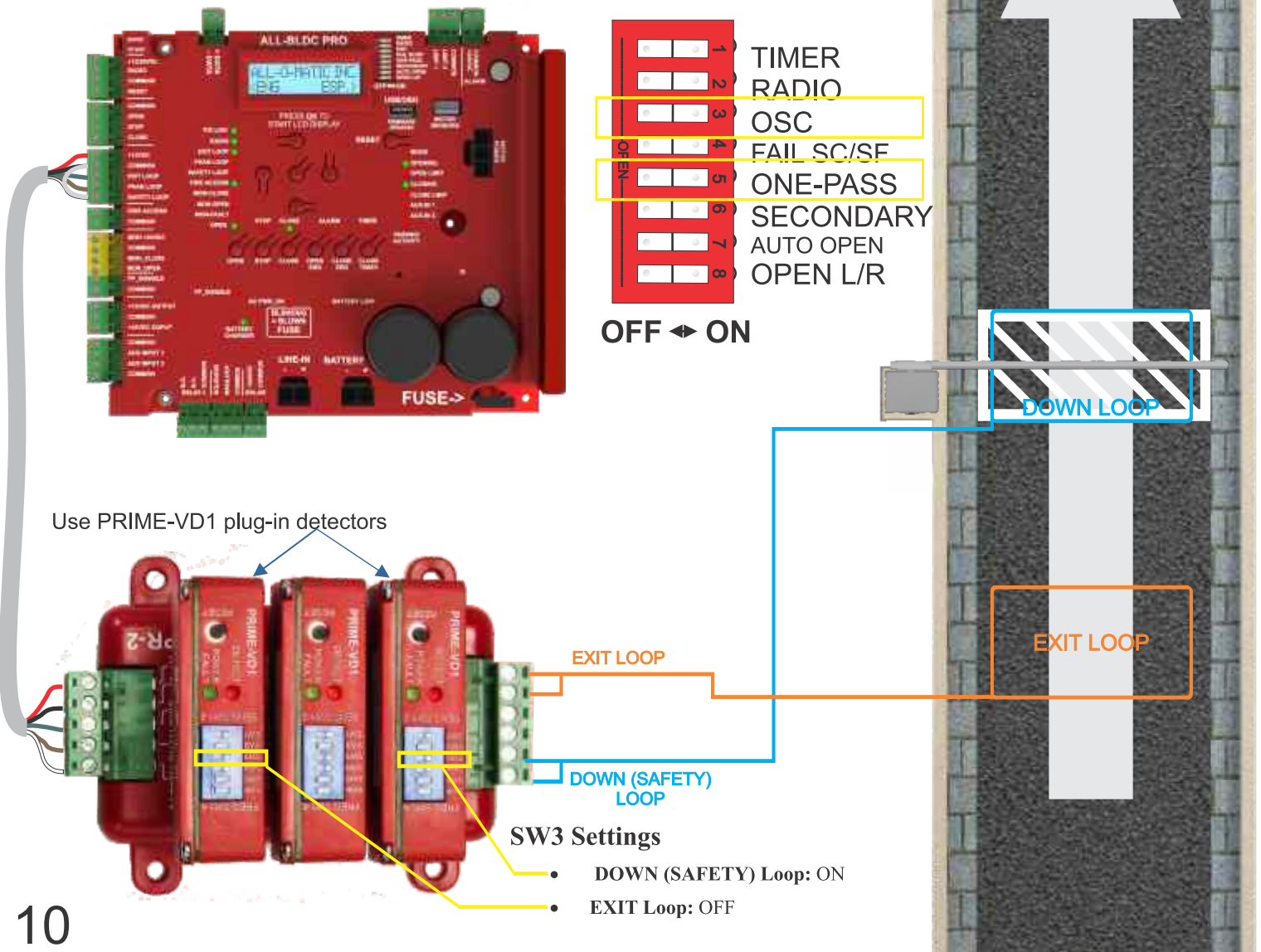

BI-DIRECTIONAL TRAFFIC LANE

BI-DIRECTIONAL Traffic Lane - Wiring and Board Configuration

1. Down Loop (Safety Loop) Setup

- Install a **PRIME-VD1** plug-in loop detector in the **Safety Loop** slot of the **LPR-2** rack.

Safety Input Modes:

The safety input can operate in two ways:

a. Down Loop Only Function

- Turn the **ONE-PASS** dip-switch **ON** & **OSC** **OFF**.

b. Down and Safety/Reverse Function

- Turn the **OSC** dip-switch **ON** & **ONE-PASS** **OFF**.

c. Safety/Reverse Only Function

- Turn the **OSC** & **ONE-PASS** dip-switches **OFF**.
- Auto close timer** setup is required for this option.

Detector Setting:

On the **PRIME-VD1** detector, set **SW3** to the **ON** position. (This configures the output as **Normally Closed (N.C.)**.)

2. EXIT Loop Setup

- Install a **PRIME-VD1** plug-in loop detector in the **Safety Loop** slot of the **LPR-2** rack.

Detector Setting:

On the **PRIME-VD1** detector, set **SW3** to the **OFF** position. (This configures the output as **Normally Open (N.O.)**.)

3. Access Control Device Wiring

- Connect the access control device to the **COMMON** and **OPEN** terminal screws on the control board.

4. (Optional) Arming Loop Setup

To use an arming loop with the access control device:

- Install a **PRIME-VD1** plug-in loop detector in the **Phantom Loop** slot of the **LPR-2** rack.

- On the **PRIME-VD1** detector, set **SW3** to the **OFF** position. (This configures the output as **Normally Open (N.O.)**.)

- Enable the Arming Loop:
 - Access the **LCD Settings Menu**.
 - Find and **Enable the ARMING loop** setting.

Note:

Once enabled, the control board will only initiate an open cycle if a command from the access control device is received **while a vehicle is detected** by the arming loop. If no vehicle is detected, access control commands will be ignored.

NOTE: The input logic of the ALL-BLDC PRO

requires only **one down loop**, even if open devices are present on both sides of the barrier arm.

In an **entry** scenario, the board will **ignore an exit loop activation one time** after the down loop has detected a vehicle passing through.

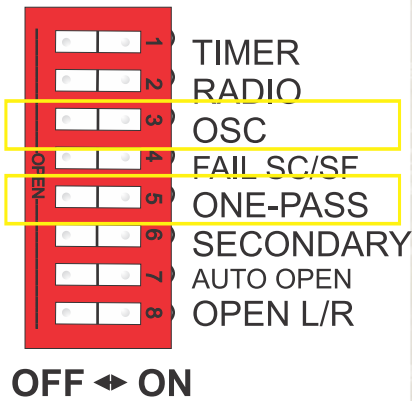

OFF ◀ ON

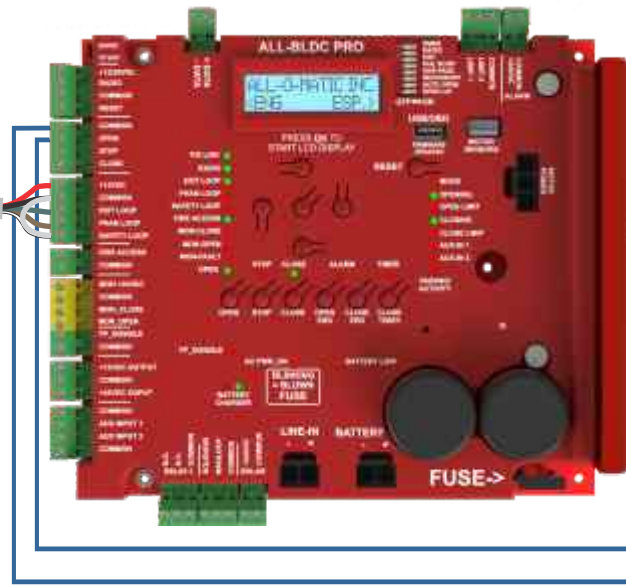

Use **PRIME-VD1** plug-in detectors

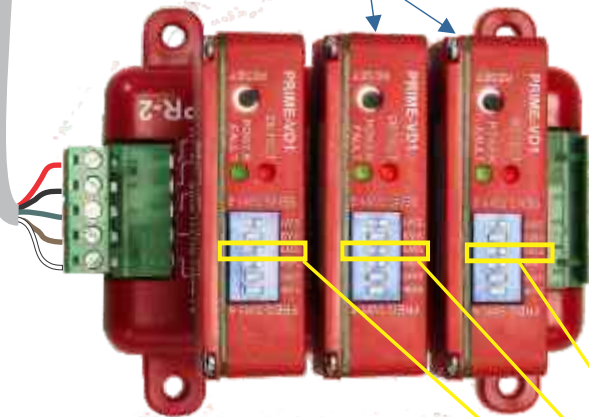

SW3 Settings

- DOWN (SAFETY) Loop: ON**
- ARMING (PHANTOM) Loop: OFF**
- EXIT Loop: OFF**

OPEN

COMMON

N.O.

COMMON

EXIT LOOP

ARMING (PHANTOM) LOOP

DOWN (SAFETY) LOOP

Optional to work with access control device

ARMING LOOP

EXIT LOOP

DOWN LOOP

TICKET DISPENSER ENTRY LANE

Ticket Dispenser Entry - Wiring and Board Configuration

1. Down Loop (Safety Loop) Setup

- Install a **PRIME-VD1** plug-in loop detector in the **Safety Loop** slot of the **LPR-2** rack.
- **Safety Input Modes:**
The safety input can operate in two ways:
 - Down Loop Only Function (see note)**
 - Turn the **ONE-PASS** dip-switch **ON**.
 - Keep the **OSC** dip-switch **OFF**.
 - Down and Safety/Reverse Function**
 - Turn the **OSC** dip-switch **ON**.
 - Keep the **ONE-PASS** dip-switch **OFF**.
- **Detector Setting:**
On the **PRIME-VD1** detector, set **SW3** to the **ON** position.
(This configures the output as **Normally Closed (N.C.)**)

2. Ticket Dispenser Device Wiring

- Connect the ticket dispenser device to the **COMMON** and **OPEN** terminal screws on the control board.

3. Ticket Dispenser Arming Loop Setup

- To use an arming loop with ticket dispenser device:
 - Install a **PRIME-VD1** plug-in loop detector in the **Phantom Loop** slot of the **LPR-2** rack.

- On the **PRIME-VD1** detector, set **SW3** to the **OFF** position.
(This configures the output as **Normally Open (N.O.)**.)
- Enable the **Arming Loop**:
 - Access the **LCD Settings Menu**.
 - Find and **enable** the **ARMING** loop setting.
 - See LCD display instructions page for more details .

Note:

Once enabled, the control board will only initiate an open cycle if a command from the access control device is received **while a vehicle is detected** by the arming loop. If no vehicle is detected, access control commands will be ignored.

NOTE: When Down Loop is configured as Down Loop only, a Down Loop activation while arm is traveling down, will not interrupt the down/close cycle. The arm will continue to complete the down/close cycle.

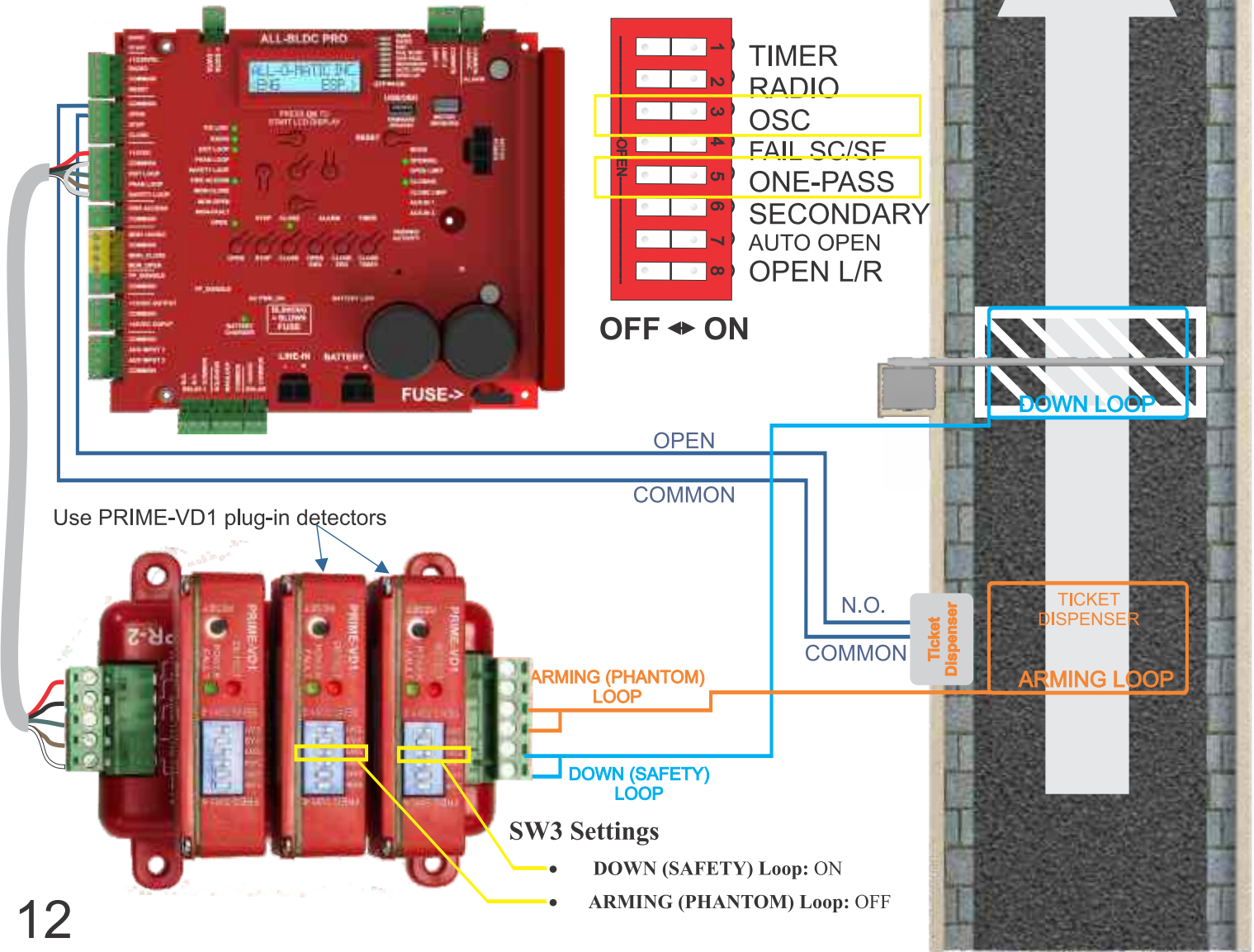

AMS (ACCESS MANAGEMENT SYSTEM) CONFIGURATION

MAGNA Q BARRIER ARM OPERATOR BOARD

BLDC PRO GATE OPERATOR BOARD

Barrier and Gate Operator Wiring

- Run four wires from board to board.
- Connect according to the chart below.

MAGNA Q TERMINAL	BLDC PRO GATE TERMINAL
AUX RELAY 1 COMMON	COMMON ABOVE OPEN INPUT
AUX RELAY N.O.	OPEN INPUT
COMMON	AUX RELAY 1 COMMON
AUX INPUT 1	AUX RELAY 1 N.O.

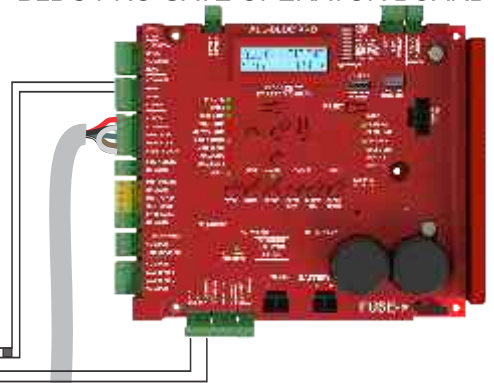
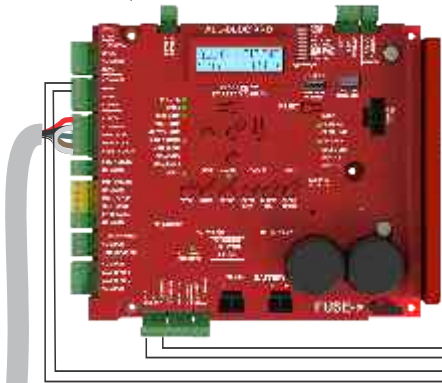

See traffic lane configuration for loop detector and loop installation

See gate operator manual for detector and loop installation

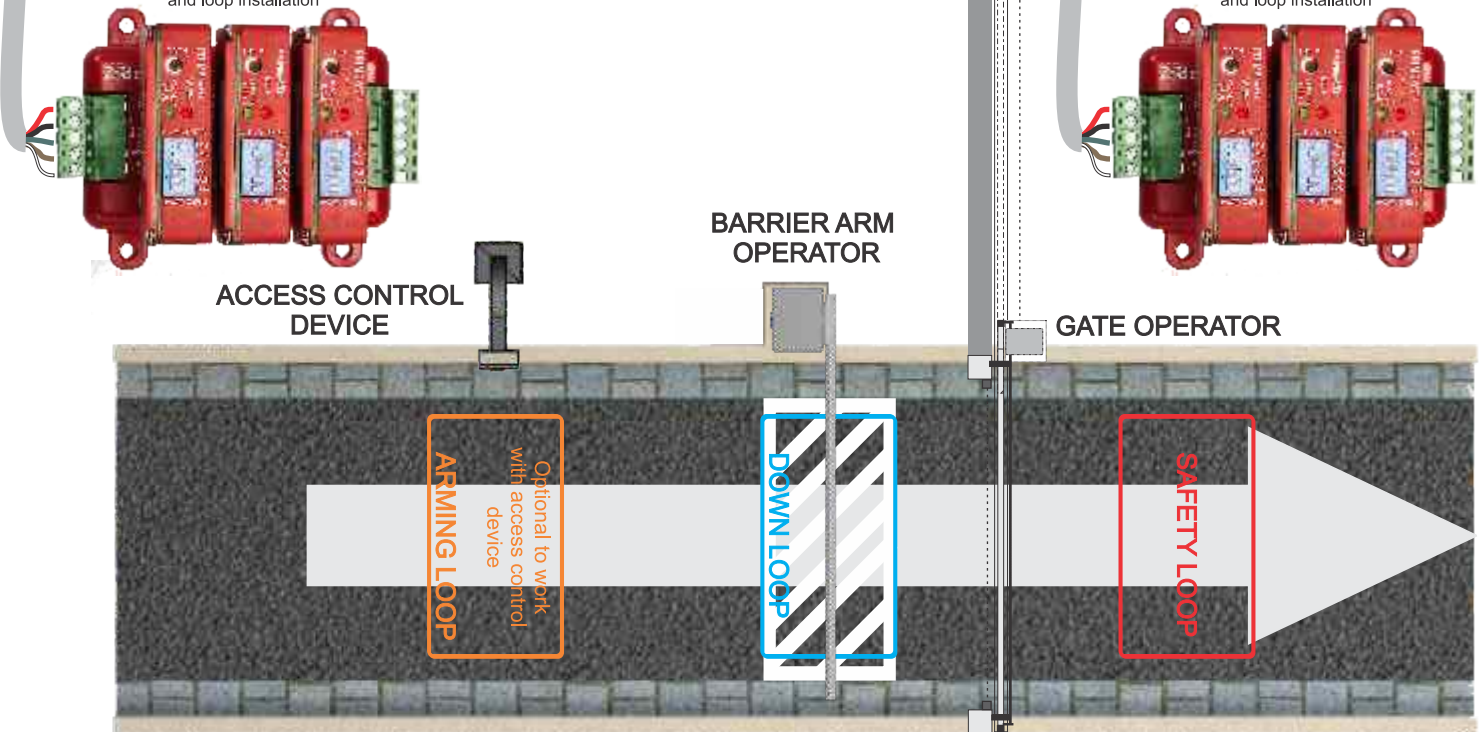

Access Management System (AMS) Overview

The Access Management System (AMS) is designed to manage and control vehicle traffic flow at facilities such as apartment complexes, businesses, and parking lots. It uses a **fast-operating barrier arm** alongside a **slower-moving security gate** to effectively regulate access.

The **barrier arm operator** quickly raises and lowers the arm to allow authorized vehicles through and immediately lowers it afterward to prevent tailgating or unauthorized entry. The **security gate operator** moves slower, providing an additional layer of access control.

Access control devices (e.g., card readers or keypads) connect to the **barrier arm operator**, which then sends open commands to the **gate operator**. The gate operator, in turn, sends a signal back once it reaches the open limit.

Setting Up the Barrier Arm and Gate Operators for AMS Mode

Barrier Arm Operator Setup

1. On the operator's LCD screen, navigate to **Settings**.
2. Locate and **enable AMS Mode**.

- When AMS Mode is active:
 - The barrier arm operator will send an **open command** to the gate using **Aux Relay 1** after receiving a valid signal from an access control device.
 - The barrier arm will **wait for the gate's open limit signal** (received via **Aux Input 1**) before raising the arm to allow vehicle passage.

Gate Operator Setup (BLDC PRO Board)

1. On the gate operator's LCD screen, navigate to **Aux Relay Settings** and press **OK**.
2. Select the **Opened Signal** option.
 - This will configure the gate operator to send an **open limit signal** back to the barrier arm operator using its **Aux Relay**.

Note: For detailed instructions on navigating the LCD display, refer to the LCD Display section.

LED STRIP AND EDGE SENSOR INSTALLATION

Instructions for Assembling Arm

1. Locate the **arm connecting link extrusion tube** and the four (4) **button socket head bolts** provided.
2. The **main arm section** comes with the **inner tube connecting link** already secured by a bolt.
 - Remove this bolt and carefully slide the **inner tube** out from the arm section.
3. Align the **threaded holes** of the **inner tube** with the **connecting holes** on the two **arm pieces**.
4. Insert the provided **button socket head bolts** through the connecting holes and into the threaded holes of the inner tube.
5. Tighten all bolts securely to complete the assembly of the two arm sections.

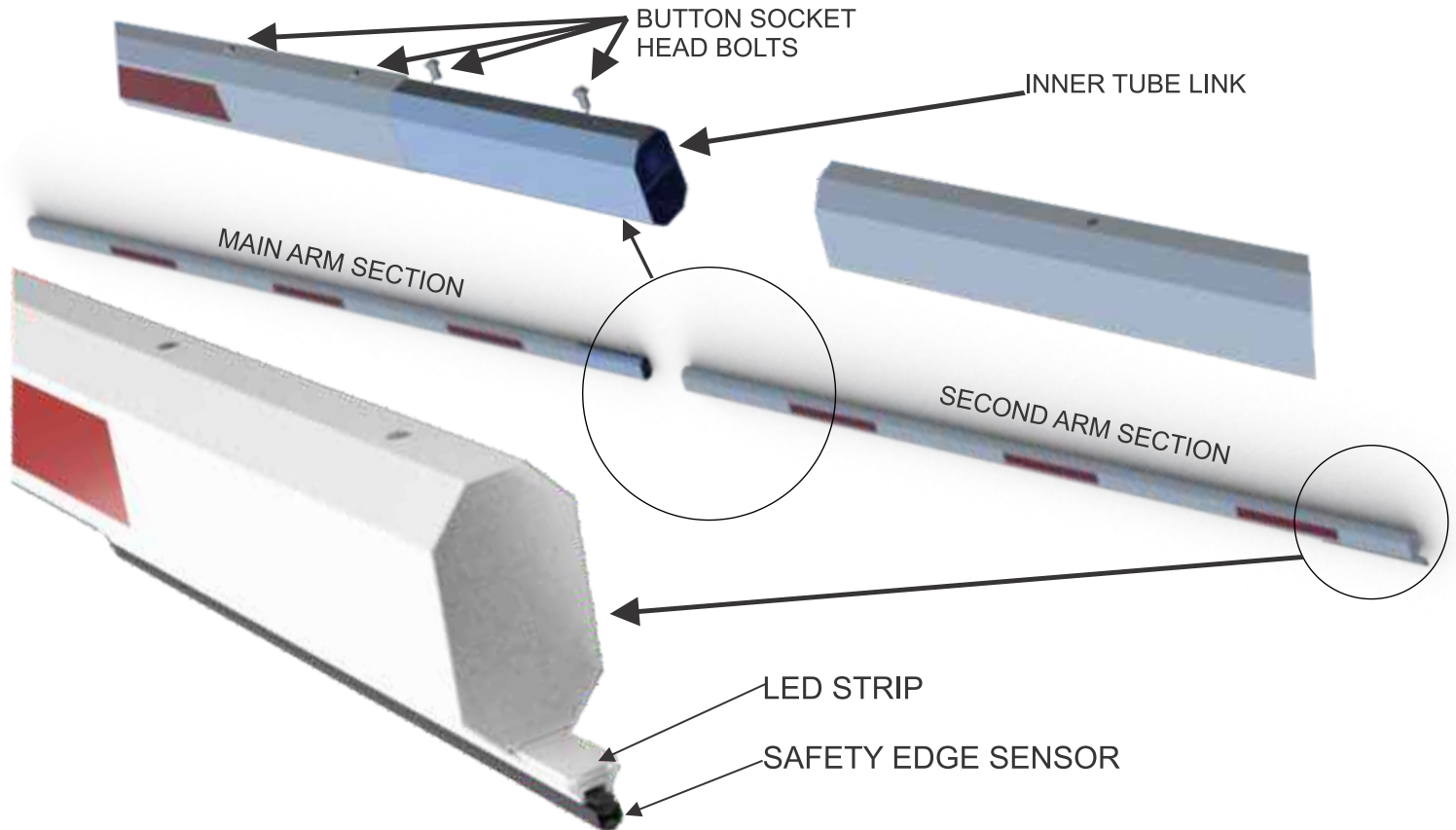

LED Strip Installation

1. Slide the **LED strip** into the bottom rail of the arm.
Tip: Apply a small amount of fluid (e.g., soapy water) to the strip to help it slide more easily.
2. Route the **LED strip wire leads** through the **pre-installed grommet** on the operator cabinet (the one closest to the traffic lane).
3. **Inside the cabinet**, continue routing the wire leads to the **bottom left** of the control board.
4. **Connect the LED strip wires as follows:**
 - **Red wire** → Positive terminal of the **12VDC power supply**.
 - **White wire** → **MAGLOCK** terminal on **AUX Relay 2**.
 - **Yellow wire** → **SOLENOID** terminal on **AUX Relay 2**.
 - **Negative wire** from the **12VDC power supply**

→ **COMMON** terminal on **AUX Relay 2**.

5. Plug in the **12VDC power supply** (provided with the LED strip) into the **auxiliary 120VAC outlet**.

Note: It's required to go into LCD settings to enable the relay LED function. See LCD settings for details.

Safety Edge Sensor Installation

1. After installing the **LED strip**, slide the **safety edge sensor** into the bottom channel of the LED strip.
2. Insert the **10K resistor plug** into the end of the sensor closest to the **tip of the arm**.
3. Insert the **wire harness plug** into the end closest to the **operator**. Route the wires into the cabinet, and continue routing inside the operator.
4. **Connect the safety edge sensor wires:**
 - One wire to **COMMON**.
 - One wire to **MON-CLOSE** terminals.

AC POWER ELECTRICAL WIRING

OPERATOR **MUST** BE PROPERLY GROUNDED!

• Grounding Requirements:

All gate operators **must** be properly grounded to mitigate the risk of electrical damage caused by nearby lightning strikes or electrostatic discharge.

- Use a **single, continuous wire** for grounding. **DO NOT** splice or join multiple wires. If damaged, replace the ground wire with a new, unbroken length. **Never** use multiple wires for grounding.
- Verify local electrical codes for approved earth ground rod types and grounding procedures, as proper grounding is essential for lightning protection of the control board.

Power Wiring Requirements:

- Use **UL-listed conduit** for enclosing power wiring to ensure compliance with safety standards.
- This gate operator support **120VAC or 240VAC single-phase power**. Set the voltage selector switch on the EMI board according to the chosen voltage. Refer to the table for proper incoming power wiring.
- Each operator must be powered by a **dedicated 20A minimum circuit** to ensure adequate power supply.

MAGNA Q	VOLTAGE	
	120VAC	240VAC
CURRENT DRAW	2.5AMPS	1.5AMPS
WIRE SIZE	MAX WIRE RUN IN FEET	
	120VAC	240VAC
#14 WIRE	180	360
#12 WIRE	280	560
#10 WIRE	450	900

Refer to the operator current draw and wire run tables above to accurately determine the appropriate wire gauge for the power run. Proper wire sizing is critical to minimizing voltage drop and ensuring reliable operation.

IMPORTANT: Due to the dual voltage configuration (120VAC/240VAC single-phase), the neutral connection of the receptacle is electrically independent from the neutral conductor of the EMI board. When operating at **120VAC**, the white wire connected to the receptacle neutral **must** be electrically bonded to the EMI board neutral. However, **when operating at 230VAC, this white wire must remain disconnected**. Failure to do so may result in damage to devices connected to the receptacle.

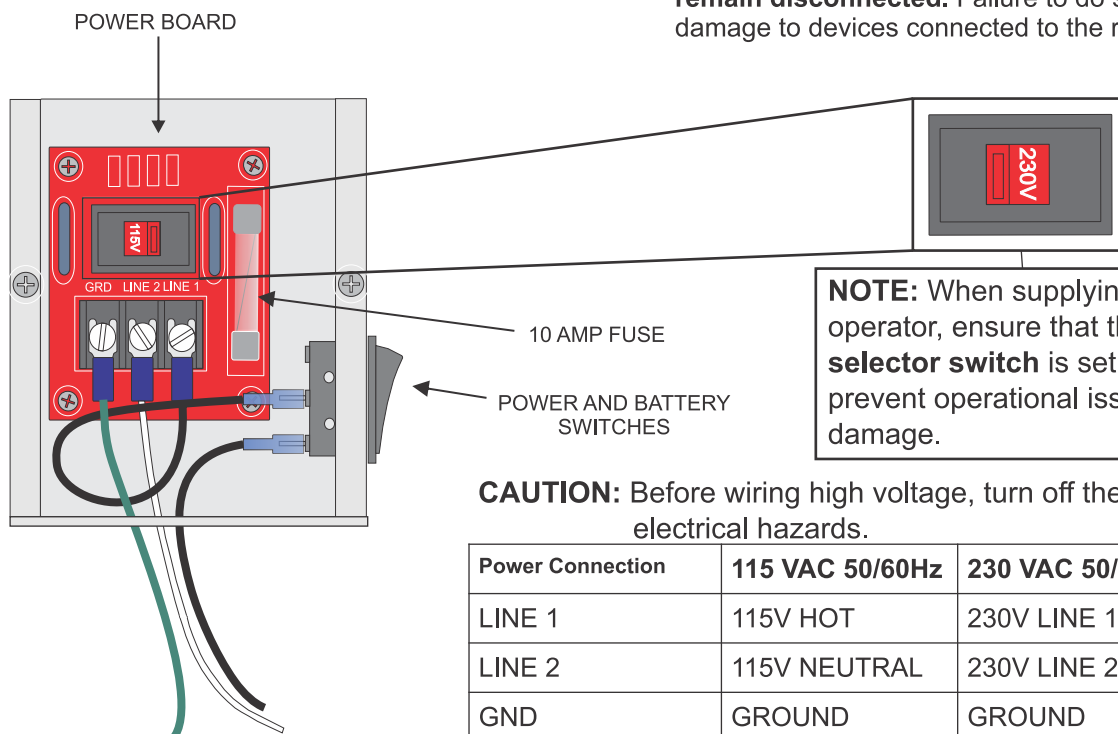

Power Connection	115 VAC 50/60Hz	230 VAC 50/60Hz Single Phase
LINE 1	115V HOT	230V LINE 1
LINE 2	115V NEUTRAL	230V LINE 2
GND	GROUND	GROUND

DIP SWITCH FUNCTIONS



NOTE: IF ANY CHANGES ARE MADE TO THE DIP-SWITCHES, PRESS THE **MAIN RESET** BUTTON TO RECOGNIZE THE CHANGES.

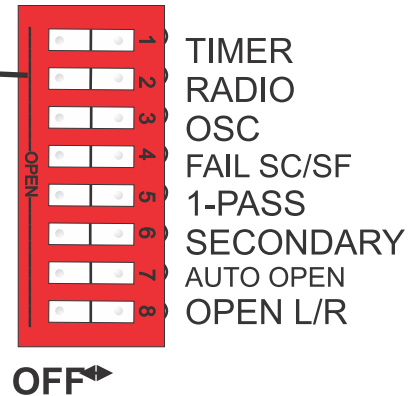

TIMER

Switch **ON** activates the automatic closing timer.
Note: down loop overrides timer. See page 21 for details.

RADIO

Switch **ON** allows the radio receiver to override the automatic close timer.
See page 21 for details.

OSC

Switch **ON** enables the down/safety loop to perform two distinct functions:

1. Once a vehicle clears the loop it lowers the arm when it is in the fully raised position.
2. If the arm is actively lowering, the loop will quickly stop and raise the arm.

Note: The **1-PASS** switch must be **OFF** for the OSC feature to function.

FAIL SC/SF (Fail-Safe / Fail-Secure)

- **ON (Fail-Safe):** During power failure, the system monitors battery voltage to ensure the barrier arm opens before full battery depletion.
- **OFF (Fail-Secure):** During power failure, the barrier arm will continue operating until battery is low, then it will lock in the closed position.

1-PASS

Switch **ON** allows the arm to raise **UP (open)** and stay up until a vehicle passes over the **DOWN/SAFETY** loop. Once the vehicle clears the loop and the arm is fully raised, it will then lower (close).

SECONDARY

Used in dual barrier arm setups.

- Switch should be **ON** only for the **secondary operator**.
- All other DIP switches must be **OFF**, except for **OPEN L/R**.
- On the **primary operator**, the **SECONDARY** switch should be **OFF**.

AUTO OPEN

Automatically opens the barrier arm during a power outage. This feature is typically required by fire departments in specific areas.

- Set this switch to **ON** if auto-open is desired.
- There is a **40-second delay** between power loss and gate opening.

OPEN L/R (Left/Right Opening)

- Switch **ON**: Right-hand arm opening
- Switch **OFF**: Left-hand arm opening

AUTO CLOSE TIME SETTING & RADIO RECEIVER WIRING

AUTO CLOSE TIMER SETTINGS

TIMER

- **ON:** Activates the automatic close timer. The gate will automatically close after a set duration, adjustable from **1 to 120 seconds (2 minutes)**. Note: If the down loop is enabled, a down loop activation will override the timer.
- **OFF:** Disables the automatic close timer. Gate operation will require manual input: **press the button to open**, and **press again to close**. Down loop will also close the arm.

To set the desired auto-close duration, use the control panel up/down buttons to select the time. Once the desired seconds are displayed, press the **OK** button to save the setting.

RADIO

- **ON:** Enables the radio receiver to override the automatic close timer. This allows the transmitter to close the gate before the auto-close timer elapses.

TIMER & RADIO dip-switches



TIMER quick access button

Radio Receiver Wiring Instructions

Receiver Types

There are two types of radio receivers:

- **3-Wire Receivers**
- **4-Wire Receivers**

3-Wire Receiver Installation

1. Connections:

- o **+12/24VDC:** Connect to the positive power input.
- o **RADIO:** Connect to the relay output.
- o **COMMON:** Connect to the shared ground/common terminal.

2. Typical Terminal Assignments:

- o **Terminal 3:** +12/24VDC
 - o **Terminal 2:** Relay output
 - o **Terminal 1:** Common (shared ground)
- Note: Always refer to the receiver's installation manual to verify terminal assignments.*

3. Voltage Selection:

- o Use the voltage selector jumper located at the top left corner of the control board to match the receiver's required voltage.

4-Wire Receiver Installation

1. Connections:

- o **+12/24VDC:** Connect the positive power wire.
- o **RADIO:** Connect one of the relay contact wires.
- o **COMMON:** Connect both the second relay contact wire and the power negative wire.

2. Voltage Selection:

- o Use the voltage selector jumper located at the top left corner of the control board to match the receiver's required voltage.

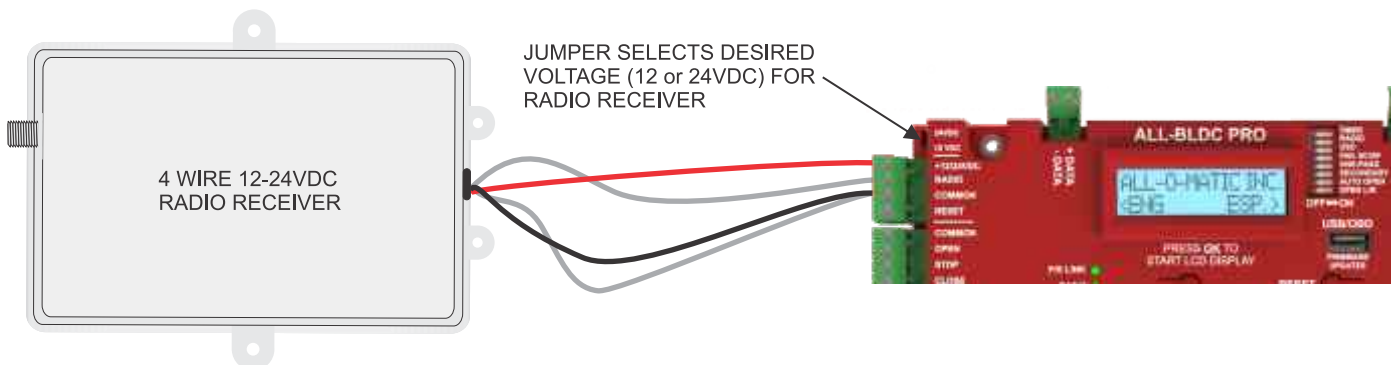

ELECTRONIC REVERSING DEVICE (ERD) ADJUSTMENT

Electronic Reversing Device (ERD) Adjustment

ALL-O-MATIC ALL-BLDC PRO control boards are equipped with an Electronic Reversing Device (ERD), which causes the barrier arm to reverse direction upon contact with an obstruction.

Factory Settings

- **Default ERD Force:** 50%

Adjustment Guidelines

- **If the arm reverses without obstruction:** The ERD force is too low.
- **If the arm does not reverse upon obstruction:** The ERD force is too high.

Adjustment Procedure

1. Accessing ERD Settings:

- o Use the quick-access **OPEN ERD** or **CLOSE ERD** buttons to enter the respective adjustment menu without navigating through the full menu.

2. Adjusting ERD Force:

- o Press and release the corresponding ERD button.
- o The ERD adjustment will appear on the LCD display.
- o Use the **DOWN** button to decrease the force if arm does not stop and reverse upon contact with an obstruction.
- o After the arm reverses at a specific force setting, increase it by 15% to ensure reliable operation.

§ *Example:* If the gate reverses at 20%, set the ERD force to 35%.

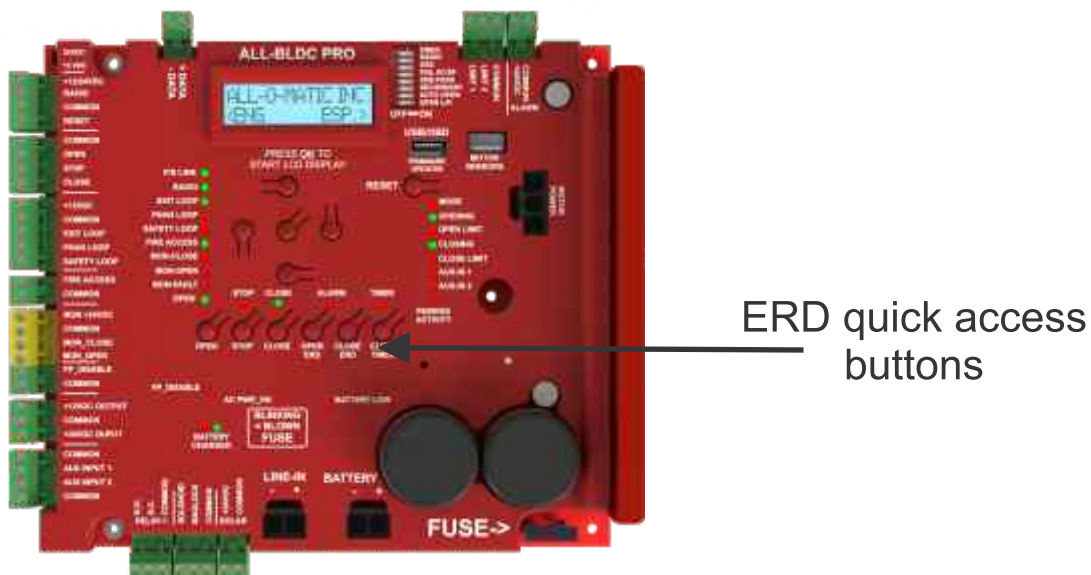

PRIMARY/SECONDARY CONNECTION

Primary/Secondary (P/S) Communication Setup

The ALL-O-MATIC BLDC PRO controller supports **wireless** and **hard-wired** Primary/Secondary communication. Accessories may be connected to **either** operator.

Preliminary Steps

1. **Individually adjust the ERDs and limit switches on each operator** as standalone machines. (Refer to the ERD and limit switch adjustment pages for details.)
2. Set the **SECONDARY DIP switch** to ON on the **secondary controller**.
3. Press the **RESET** button on the **secondary controller**.

Wireless Setup

1. On the **first unit**, press and hold the **UP** button. While holding **UP**, press and release **RESET** (do **not** release **UP** yet).
→ LCD will display a message to **setup the other unit**, then show **default channel 1**.
→ Release **UP**.
2. Repeat **step 1** on the **second unit**.
 - o Confirm that **both displays show the same channel**.
 - o Ensure the **SECONDARY DIP switch** is

ON on the secondary operator.

3. When both units display the **same channel** and correct DIP settings, they will automatically **link up** and the **P/S LINK LED** will turn **ON**.

NOTE: If multiple operator sets are in use with wireless communication and are within range of each other, each set must run on different channels. For instructions on how to change channels, see display menu settings pages.

Hard-Wired Setup

1. On the **first unit**, press and hold the **DOWN** button. While holding **DOWN**, press and release **RESET** (do **not** release **DOWN** yet).
→ LCD will display **WIRED MODE**.
2. Repeat **step 1** on the **second unit**.
 - o Confirm that DIP settings and preliminary adjustments are complete.
3. Wire the two operators **per the diagram**, ensuring:
 - o **DATA+ to DATA+**
 - o **DATA- to DATA-**
→ Once connected, the units will **link up** and the **P/S LINK LED** will turn **ON**.

PRIMARY CONTROLLER



SECONDARY CONTROLLER

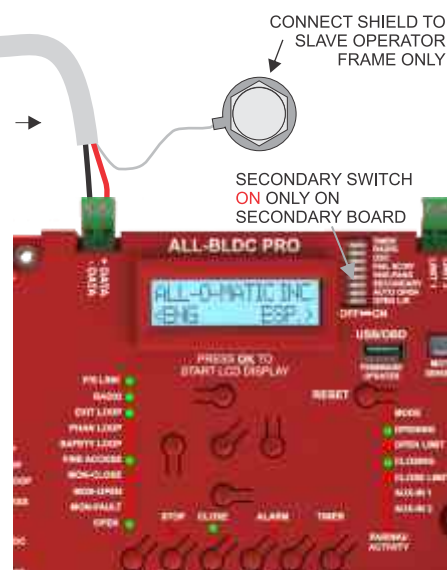

PROGRAMMABLE RELAY AND LEAF DELAY

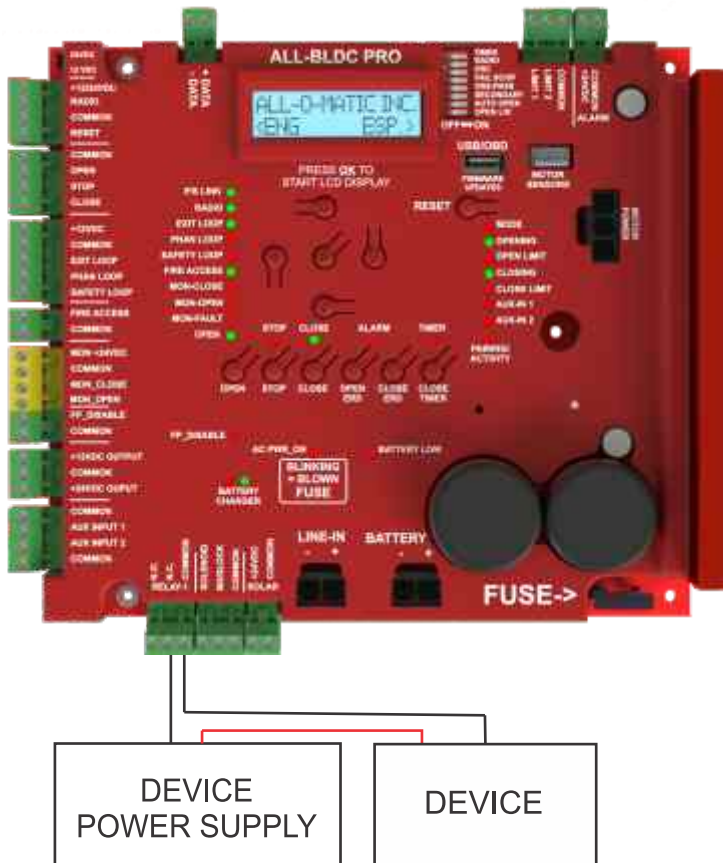

ENTERING THE LCD DISPLAY MENU

- 1. Wake the Display:**
Press the OK button twice to wake up the screen.
- 2. Enter English Menu:**
When the welcome message appears, press the < (LEFT) button to access the English menu.
- 3. Access Settings:**
Use the UP or DOWN buttons to scroll through the options.
When the cursor is on SETTINGS, press OK.
- 4. Available Settings:**
Within SETTINGS, you'll find options such as:
 - o AUXILIARY RELAY
 - o LEAF DELAY
- 5. Navigation Tips:**
 - o Use the UP or DOWN to scroll
 - o Use the < (LEFT) button to return to the previous menu

MAGNA Q – Auxiliary Relay Configuration

The MAGNA Q system includes **two programmable relays** (N.O. or N.C.), each with **four customizable configurations**.

Accessing Auxiliary Relay Settings

- From the **LCD display**, navigate to:
 - o **ENGLISH** menu →
 - o **SETTINGS** →
 - o Scroll down to **AUXILIARY RELAYS** →
 - o Press **OK**
- You'll now see:
 - o **AUX RELAY ONE**
 - o **AUX RELAY TWO**
- Select the desired relay and press the **OK** button to configure it.

Relay Configuration Options

Each relay can be set to one of the following four options:

GATE OPEN COMMAND (Relay One Only) see AMS page for wiring.

- Used to send an OPEN command to a gate operator.
Run two wires from AUX Relay 1 COMMON and N.O. contacts to gate operator open command input.

- AMS (Access Management System)** mode is to manage the access opening sequence of a gate and barrier arm operator combination

LSI SIGNAL (Relay Two Only)

- Toggles the **RED/GREEN LED Strip Indicator Accessory**
- Activates while the **Arm is in motion**

MOVING SIGNAL (Relay 1 or 2)

- Activates the relay **whenever the Arm is in motion**
- Ideal for motion-based signaling or alerts

OPENED SIGNAL (Relay One or Two)

- Activates the relay **when the Arm is fully raised**
- Useful for notifying the end user of the gate's open status

CLOSED SIGNAL (Relay One or Two)

- Activates the relay **when the Arm is fully lowered**
- Useful for indicating the gate is securely closed

MONITORED ENTRAPMENT PROTECTION DEVICE WIRING

OVERHEAD VIEW OF DRIVEWAY

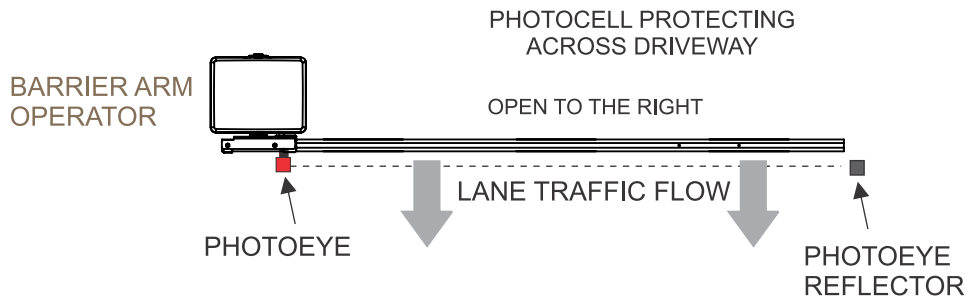

WIRING ENTRAPMENT DEVICE TO DC BOARD

WIRING DEVICE ACROSS DRIVEWAY / CLOSING DIRECTION (MON_CLOSE)

WIRING THE AOM-RED-EYE (NOT INCLUDED WITH OPERATOR) TO THE CIRCUIT BOARD

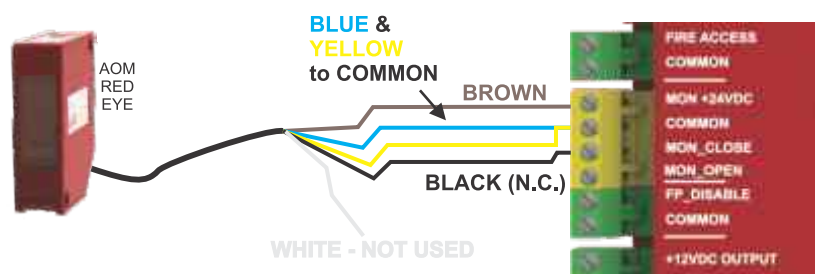

WIRING DEVICE FOR OPENING DIRECTION (MON_OPEN)

WIRING THE AOM-RED-EYE (NOT INCLUDED WITH OPERATOR) TO THE CIRCUIT BOARD

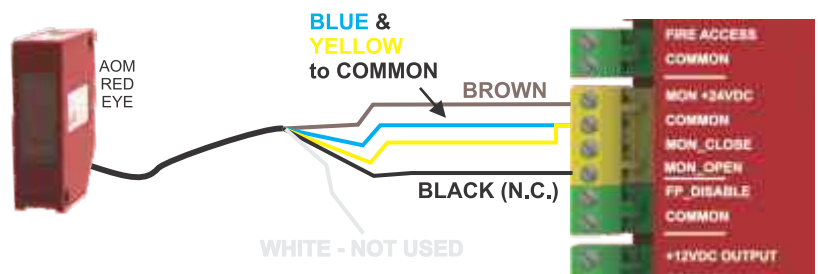

ALL-BLDC PRO offers the 10K termination alternate option. Connect 10K sensor contacts to COMMON and MON-OPEN or MON-CLOSE as shown below.

Close contact edge with 10K termination

Open contact edge with 10K termination

Additionally, AUX INPUT 1 and 2 can be used to wire additional entrapment protection devices (10K or N.C. termination). For N.C. devices, power must be connected to MON +24VDC. For 10K devices power could be connected to the constant +12VDC or +24VDC if it requires power. See LCD display page for details of programming inputs.

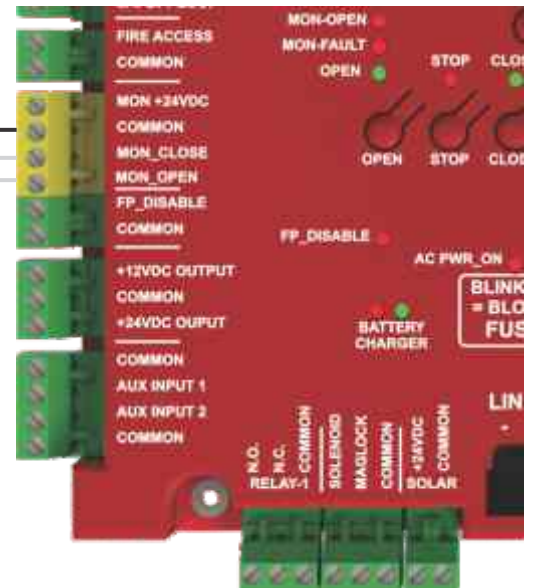

3RD PARTY MONITORED ENTRAPMENT PROTECTION DEVICE CONNECTIONS

- There are 2 types of sensors that can be connected to the gate operator for UL 325 monitored entrapment compliance: non-contact sensors (photo eye) and contact sensors (edge sensors).
- Monitored entrapment protection devices use 4 wires to connect to the board. From the device, connect the **RELAY COMMON** to the board **COMMON** and the **NORMALLY CLOSED** relay contact to the assigned **MON_OPEN** or **MON_CLOSE** input. **MON +24VDC** and **COMMON** must be used to power these devices and properly monitor them.
- **IMPORTANT:** ALL-BLDC PRO can also work with 10K termination devices. See bottom of previous page for wiring details.
- **NOTE:** The power to the **MON +24VDC** terminal will be off when the gate is at rest (not moving). It will be normal to see the **MON_OPEN** and **MON_CLOSE** LEDs when the gate is closed. If the auto close timer is **OFF** it will do the same when the gate is at rest in the open position. Also, if no devices are connected both of these lights will stay ON.
- Please refer to the device manufacturer wiring instructions for details (on next page), making sure to follow the normally closed wiring directions. Some devices may work on monitoring interfaces other than normally closed.
- Should there be a need for more than 1 entrapment protection device for each direction, **AUX INPUT 1** and **AUX INPUT 2** could be used as MONITORED input expansion. See LCD display page for programming details.

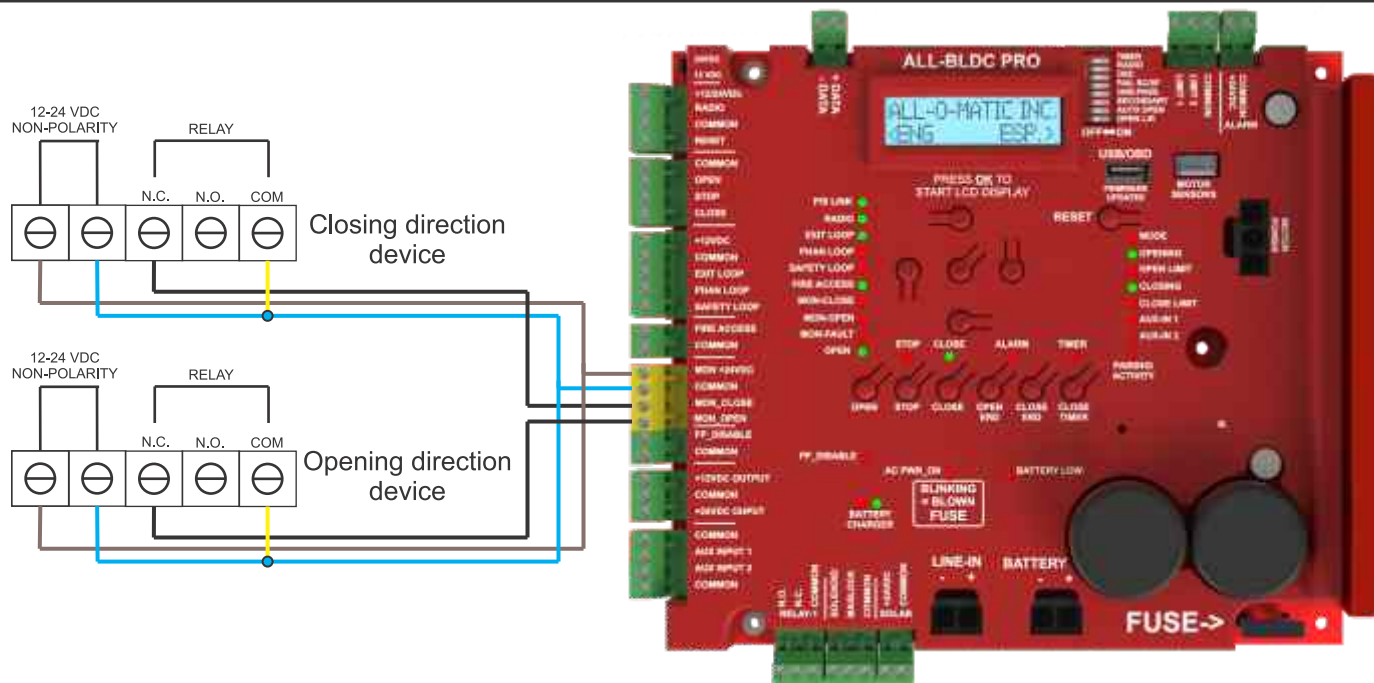

MON_CLOSE (LED will indicate when an obstruction is detected or device is not present)

This input is only for the monitored entrapment protection device for the close direction. When the barrier arm is closing, it will open to the full open position if an obstruction is sensed and resets the automatic close timer. This input does nothing in the opening direction. If a device is not connected or sensed during power up, board assumes one is not required and will operate normal (it's normal to see LED on). If one is required and installed, board will monitor it once it's sensed.

MON_OPEN (LED will indicate when an obstruction is detected or device is not present)

This input is only for the monitored entrapment protection device for the open direction (only when required). If board does not sense a device connected, it will assume on is not required. When the barrier arm is opening, it will reverse for 2 seconds and stop if it senses an obstruction. This input does nothing in the closing direction. If a device is connected and the board detects a fault (MON_FAULT LED will turn on). Once the obstruction is cleared, the gate will operate normally. (it is normal to see the LED on if a device is not used/connected).

ALTERNATE MONITORED ENTRAPMENT PROTECTION DEVICE WIRING

OMRON E3K-R10K4-NR		
SWITCH	CONTACT	BOARD TERMINAL
LIGHT ON	N.O.2	MON_CLOSE OR MON_OPEN
	C.2	COMMON
	24 TO 240 VAC	COMMON
	24 TO 240 VAC	MON_12/24VDC

EMX IRB-MON		
SWITCH	CONTACT	BOARD TERMINAL
SW1 - OFF	N.C.	MON_CLOSE OR MON_OPEN
SW2 - OFF	COM	COMMON
SW3 - ON	POWER/VRX	COMMON
SW4 - OFF	POWER/VRX	MON_12/24VDC

EMX IRB-325	
CONTACT	BOARD TERMINAL
N.C.	MON_CLOSE OR MON_OPEN
COM	COMMON
POWER	COMMON
POWER	MON_12/24VDC

EMX NIR-50-325	
WIRE	BOARD TERMINAL
BLACK	MON_CLOSE OR MON_OPEN
WHITE	COMMON
BLUE	COMMON
BROWN	MON_12/24VDC

EMX IRB-RET		
SWITCH	CONTACT	BOARD TERMINAL
SW1 - OFF	N.C.	MON_CLOSE OR MON_OPEN
SW2 - OFF	COM	COMMON
SW3 - OFF	POWER/VRX	COMMON
SW4 - ON	POWER/VRX	MON_12/24VDC

EMX WEL-200	
CONTACT	BOARD TERMINAL
RELAY CLOSE (NC) RELAY OPEN (NC)	MON_CLOSE MON_OPEN
RELAY CLOSE (COM) RELAY OPEN (COM)	COMMON COMMON
POWER	COMMON
POWER	MON_12/24VDC

MILLER EDGE RBAND 6 WIRES FOR 1 EDGE - 8 WIRES FOR 2 EDGES		
SWITCH	CONTACT	BOARD TERMINAL
SW 1 - ON	N/C N/C	MON_CLOSE MON_OPEN
SW 2 - ON	COM COM	COMMON COMMON
SW 3 - ON	COM A.TEST	COMMON MON_12/24VDC
SW 4 - ON	12/24 (+) AC/DC	24-VDC GROUND

MON_CLOSE = PROTECTS ACROSS THE DRIVEWAY/CLOSING DIRECTION
 MON_OPEN = PROTECTS THE REAR SLIDE / OPENING DIRECTION

ACCESSORY WIRING

The **ALL-BLDC PRO** controller has auxiliary **+12VDC** and **+24VDC** terminals that provide up to 750 mA on **+12VDC** and 750mA on **+24VDC** to power accessories. If the total current draw of the accessories exceeds the rated current for any of the +12VDC or +24VDC terminals, a separate power supply (transformer) is required.

IMPORTANT: From factory, we include wire jumpers on N.C. inputs. When installing a safety loop detector or a stop push button (**STOP** input), make sure to remove the wire jumper between the **COMMON** and **SAFETY LOOP** terminal for the safety detector and/or wire jumper between **STOP** and **COMMON** for a stop push button.

AUX INPUT 1 AND AUX INPUT 2, could be programmed to different functions. Depending on the function, the input can be N.O., N.C. or 10K termination for entrapment protection devices. See LCD display page for details on input function details.

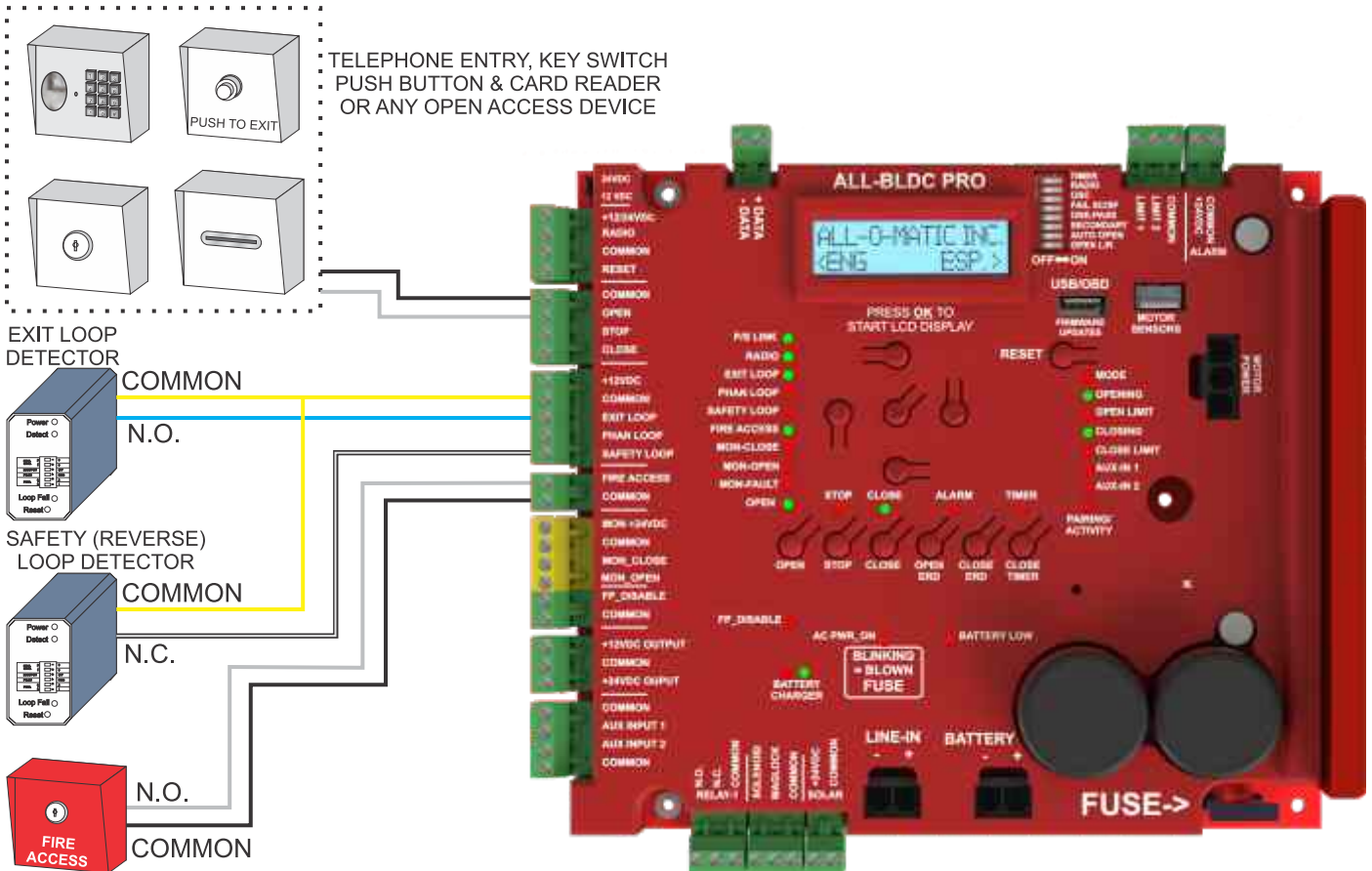

LED Strip Connection Using AUXILIARY Relay 2 (Lock Relay)

The **ALL-BLDC PRO** controller utilizes **AUXILIARY Relay 2** (Lock Relay) to control a **Red/Green LED Strip Indicator**. A dedicated power supply is required to operate the LED strip (included with the LED strip accessory).

Power Supply Connection:

1. Plug the LED strip power supply into the auxiliary 120VAC outlet on the control board.

LED Strip Wiring Instructions:

2. **Power Supply and LED Strip**
 - o **Positive (striped) wire** from power supply → Connect to **Red wire** of the LED strip harness.
 - o **Negative (solid black) wire** from power supply → Connect to **COMMON terminal** on **AUXILIARY Relay 2 (Lock Relay)**.
 - o **White wire** → Connect to the **MAGLOCK terminal**.
 - o **Yellow wire** → Connect to the **SOLENOID terminal**.

Ensure all connections are secure and polarity is correct to prevent malfunction.

ACCESSORY WIRING (CONT.)

- A three button station and reset push button are integrated on the board to make limit and ERD adjustments easier.
- An external three button station may also be installed. See diagram below for wiring instructions.
- **NOTE:** STOP jumper must be removed if a three button station is installed.

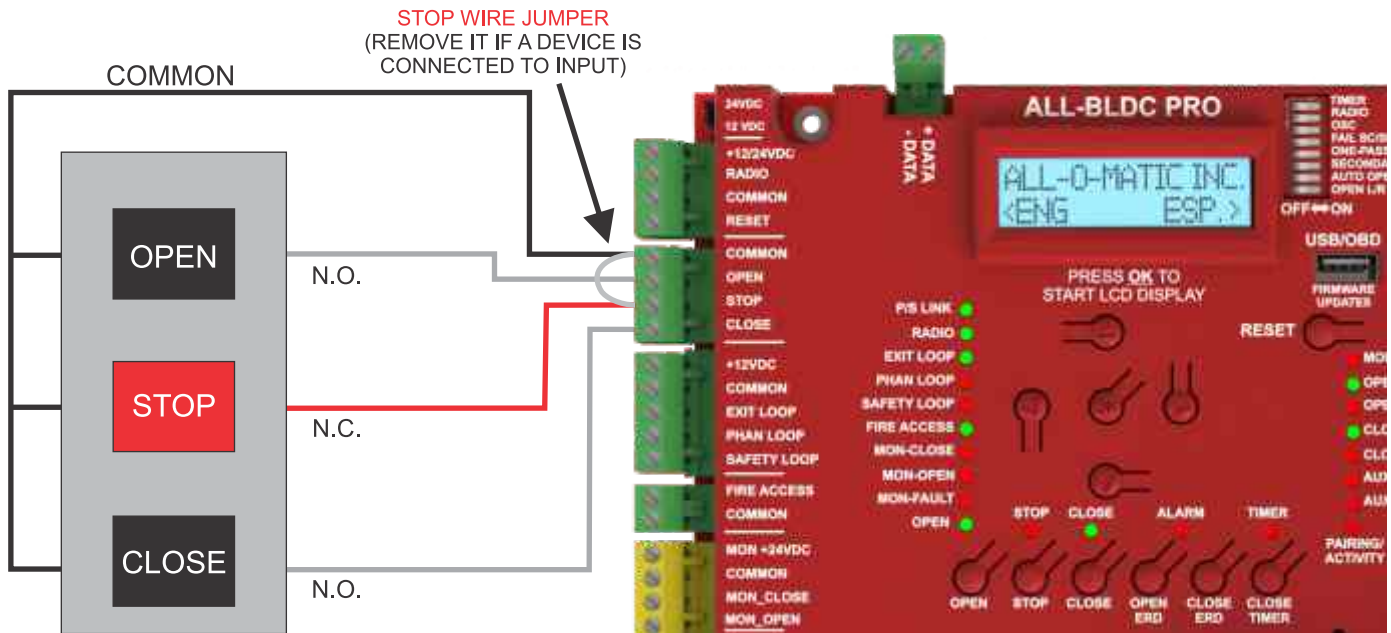

LED Strip Connection Using AUXILIARY Relay 2 (Lock Relay)

The **ALL-BLDC PRO** controller utilizes **AUXILIARY Relay 2** (Lock Relay) to control a **Red/Green LED Strip Indicator**. A dedicated power supply is required to operate the LED strip (included with the LED strip accessory).

⚡ Power Supply Connection:

1. Plug the LED strip **power supply** into the **auxiliary 120VAC outlet** on the control board.

☐ LED Strip Wiring Instructions:

2. Power Supply and LED Strip

- o **Positive (striped) wire** from power supply → Connect to **red wire** of the LED strip harness.
- o **Negative (solid black) wire** from power supply → Connect to **COMMON terminal** on **AUXILIARY Relay 2 (Lock Relay)**.
- o **White wire** → Connect to the **MAGLOCK terminal**.
- o **Yellow wire** → Connect to the **SOLENOID terminal**.

☑ Ensure all connections are secure and polarity is correct to avoid malfunction.

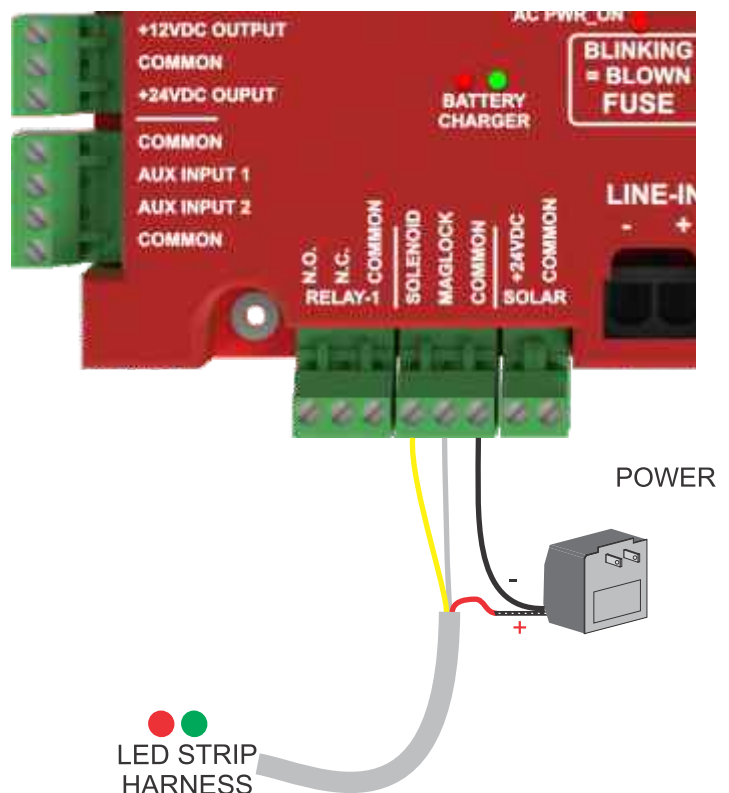

SOLAR PANEL CONNECTION

The solar panel input requires a minimum 24VDC, 40-watt panel. The charging circuit supports up to 80 watts. With two (2) 14Ah, 12VDC batteries, a receiver, and two (2) monitored entrapment devices connected, the operator can provide approximately 100 cycles per day.

Be sure to connect solar panels to the **SOLAR** input. The onboard solar battery regulator features MPPT (Maximum Power Point Tracking) technology, offering greater efficiency than standard regulators.

For solar installations, upgrade the batteries based on usage demands. When the application requires more than 80 watts of solar power, an external charge controller regulator is necessary. See the next page for information on external solar system configuration.

For details on solar applications (e.g., panel size, battery capacity, etc.), please contact All-O-Matic.

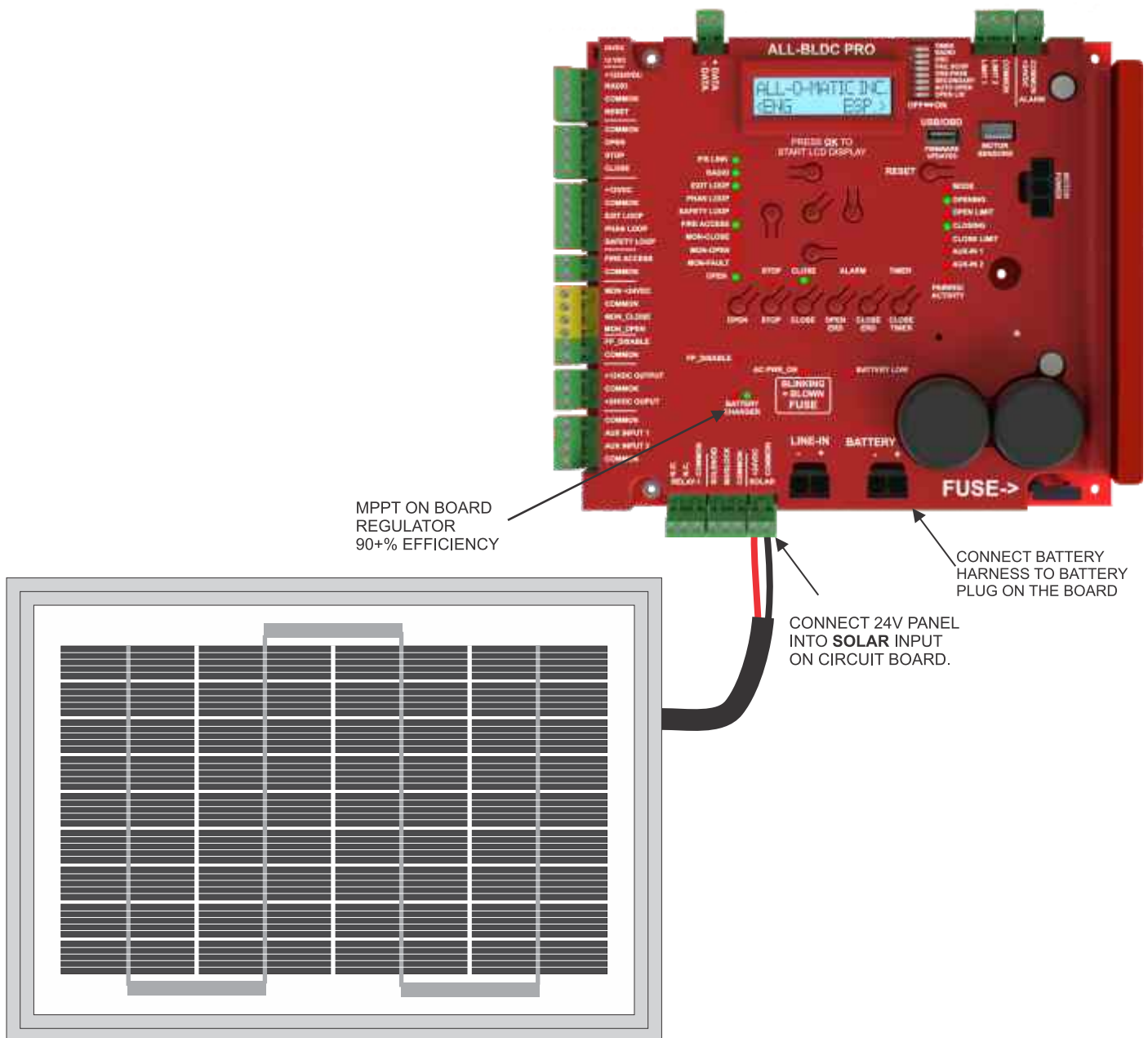

EXTERNAL SOLAR SYSTEM INSTALLATION

When using an external solar package, connect the batteries directly to the BATTERY input. The batteries must be appropriately sized to meet the application requirements. See wiring diagram below.

For information on solar applications (e.g., panel sizing, battery capacity, etc.), please contact All-O-Matic.

IMPORTANT: If more than two solar panels are used, special wiring precautions are required to prevent damage to the batteries and/or the charge controller regulator. If 12VDC panels are used, they must be wired in series to achieve 24VDC. If 24VDC panels are used, they must be wired in parallel.

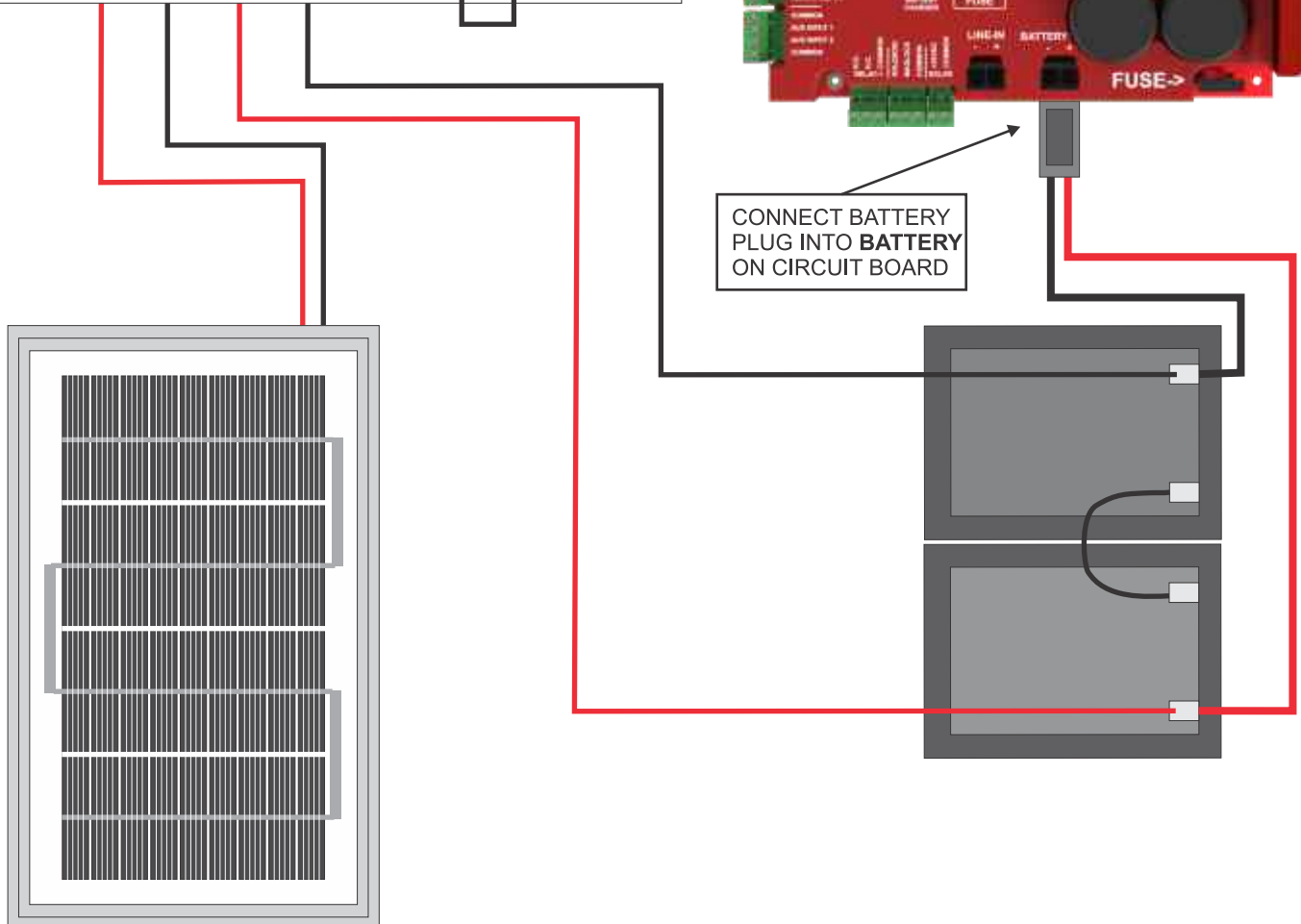
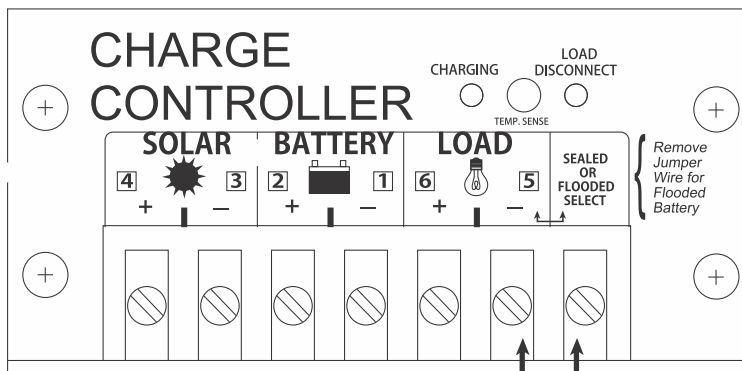

LED DIAGNOSTICS

P/S LINK

ON when primary/secondary communication is active. Will blink if dip-switch SECONDARY is ON and waiting to establish communication with primary.

RADIO

ON when the RADIO input is activated (closed circuit to common).

EXIT LOOP

ON when the EXIT input is activated (closed circuit to common).

PHANTOM LOOP

ON when the PHANTOM LOOP input is activated (closed circuit to common).

SAFETY LOOP

ON when the SAFETY LOOP input is activated (open circuit to common).

FIRE ACCESS

ON when the FIRE ACCESS input is activated (closed circuit to common).

MON_CLOSE

ON when the MON_CLOSE input is activated (open circuit to common) or when a device is not installed.

MON_OPEN

ON when the MON-OPEN input is activated (open circuit to common) or when a device is not installed.

MON_FAULT

ON when a fault has been detected on devices in MON-OPEN or MON-CLOSE inputs (if a device isn't working correctly or it isn't present).

OPEN

ON when the OPEN inputs or OPEN push button are activated (closed circuit to common). It will be ON together with other inputs. See inputs page for more details.

STOP

ON when the STOP input or STOP push button are activated (open circuit to common).

CLOSE

ON when the CLOSE input or CLOSE push button are activated (closed circuit to common).

ALARM

Turns on for 5 minutes (alarms also goes off) when the operator goes into shut down mode due to the gate

hitting an obstruction (ERD) twice before reaching fully closed position.

TIMER

Blinks every 1/2 second when the timer is counting down to close automatically.

MODE

Blinks **once** every two seconds when there is a problem with the motor **sensor** feedback. Blinks twice every **two seconds** when a **motor overload** is detected. Blinks **three** times every two seconds when the gate is **jammed**.

OPENING

ON while the gate is opening.

OPEN-LIMIT

ON while the limit nut is activating the open limit switch.

CLOSING

ON while the gate is closing.

CLOSE-LIMIT

ON while the limit nut is activating the close limit switch.

AUX-IN 1

ON while AUX INPUT 1 is activated (closed circuit to common).

AUX-IN 2

ON while AUX INPUT 2 is activated (closed circuit to common).

FP_DISABLE

ON when the Arm is not in place.

AC/PWR ON

ON when AC power is on. It will also blink about every 1/2 second to indicate the main board fuse is blown.

LOW-BATTERY

ON when the batteries are low, turned off or disconnected.

TIPS: When troubleshooting, it is important to note what lights are ON. It is very helpful to pay attention to the lights as they tell us what the board is doing and what inputs are active. When calling ALL-O-MATIC for technical support please have the name of the lights that are ON in the control board. This will speed up the process to get the gate operator up and running.

TECHNICAL TIPS

Operator Symptom	Solutions (diganose)
Opening or closing LEDs are on, but arm doesn't move	If AC PWR_LED is blinking, replace the fuse at bottom right corner of the board. After replacing the fuse and before a signal is given, inspect the arm and limit switches to ensure it's not bound up and that the limit switches are set correctly. If arm still doesn't run, check motor harness and make sure it is plugged in correctly and no wires are loose.
Radio receiver doesn't work	Jumper at top left corner by factory is set on 12VDC. If the receiver requires 24VDC, move the jumper to 24VDC.
AC PWR_ON LED is off	Make sure main high voltage power is connected and AC power switch is in the ON position. If that is fine, check 10Amp fuse in EMI board in the power box. If it's blown, check rectifier, it may also be damaged and need to be replaced along with the 10Amp fuse.
Arm opens very slow	Check limit switch adjustment. Usually when arm opens very slow it is due to arm hitting the positive stop before close limit swith activates. Check the variable speed setting to be sure it's set at 100%. Check that the AC power is turned ON and that the AC PWR_ON LED is lit. Also, make sure limit learning has been done. See below.
Learning the limits for soft stop function.	Set the arm in closed position with the close limit activated. Press and release the RESET button on board. Run the arm a full cycle (full open and full close) without interruption. The first cyccle will be slower while learning the distance between limits. It will run full speed once limits have been learned.
Arm does not run and ALARM LED is ON	Arm is in Shut down mode due to obstruction detection. Press red RESET button outside control box next to radio connector. Run the arm and inspect arm is not bound up or jammed. Test ERD sensitivity. See ERD adjusment page for details on the adjustment.
Arm does not run and FP_DISABLE is ON	Check and make sure arm is in place properly. Arm attachment bracke has sensor and it disables the operator when are is not in place, wires are damaged or disconnected.
Arm does not run and STOP LED is ON	Check STOP input device and make sure it is not activated. Remember, this input is N.C. and LED will stay on if the wrong contact is used.
Arm does not run and MODE LED blinks	See LED DIAGNOSTICS for details on the meaning of the blinks.
Arm doesn't close	Check LEDs, any of the following input LEDs will prevent arm from closing. Check inputs for LEDs that are ON: RADIO, OPEN, STOP, EXIT LOOP, PHAN LOOP, SAFETY LOOP, FIRE ACCES, MON-CLOSE (check wiring and alignment), FP_DISABLE, (AUX INPUT 1 & 2, depending on programmed function). Also, check if AC PWR_ON LED is OFF(if it's OFF and dip-switch 4 or 7 are ON, arm will remain open).
Arm doesn't open	Check LEDs, any of the following input LEDs will prevent arm from opening. Check inputs for LEDs that are ON: STOP, CLOSE, MON-OPEN, FP-DISABLE and AUX INPUT 1 or 2 (depending on programmed fuction). Also, check if AC PWR_ON LED is OFF (if it's OFF and dip-switch 4 is OFF, arm will remain closed if battery is low)
Arm stops and reverses before reaching limits	Check ERD. If no obvious obstruction is present, it may need to be adjusted and increase the force for the direction it is stopping. See ERD adjustment page for details.
Arm stops and reverses open	Check LEDs and see if any of them turn ON when arm reverses. It may be that the arm movement might be activating that device. See above the devices that prevents arm from closing.

AUX INPUT 1 & 2 PROGRAMMING

AUX INPUT 1 Functions

- 1. EMERGENCY OPEN** (Factory Default)
 - Devices connected to this input will raise the Arm and override any MON-OPEN devices.
 - Use a **Normally Open (N.O.)** contact.
- 2. OPEN-CMD**
 - Devices connected to this input will raise the Arm.
 - Use a **Normally Open (N.O.)** contact from the device.
- 3. CLOSE-CMD**
 - Devices connected to this input will lower the Arm.
 - Use a **Normally Open (N.O.)** contact.
- 4. MON-OPEN**
 - Expands open-direction entrapment protection.
 - Use a **Normally Closed (N.C.)** contact or a **10K termination** on the device.
 - **IMPORTANT:** If using an N.C. contact, connect the device to **MON +24VDC** for power.
- 5. MON-CLOSE**
 - Expands close-direction entrapment protection.
 - Use a **Normally Closed (N.C.)** contact or a **10K termination** on the device.
 - **IMPORTANT:** If using an N.C. contact, connect the device to **MON +24VDC** for power.
- 6. GATE OPEN LIMIT**
 - Used for **AMS (Access Management System) mode**.
 - Receives the **open limit** signal from the gate operator.

7. STOP-CMD

- Devices connected to this input will stop the Arm.
- Use a **Normally Closed (N.C.)** contact.

AUX INPUT 2 Functions

- 1. EMERGENCY CLOSE** (Factory Default)
 - Devices connected to this input will lower the Arm and override any MON-CLOSE devices.
 - Use a **Normally Open (N.O.)** contact.
- 2. OPEN-CMD**
 - Devices connected to this input will raise the Arm.
 - Use a **Normally Open (N.O.)** contact from the device.
- 3. CLOSE-CMD**
 - Devices connected to this input will lower the Arm.
 - Use a **Normally Open (N.O.)** contact.
- 4. MON-OPEN**
 - Expands open-direction entrapment protection.
 - Use a **Normally Closed (N.C.)** contact or a **10K termination** on the device.
 - **IMPORTANT:** If using an N.C. contact, connect the device to **MON +24VDC** for power.
- 5. MON-CLOSE**
 - Expands close-direction entrapment protection.
 - Use a **Normally Closed (N.C.)** contact or a **10K termination** on the device.
 - **IMPORTANT:** If using an N.C. contact, connect the device to **MON +24VDC** for power.
- 6. STOP-CMD**
 - Devices connected to this input will stop the Arm.
 - Use a **Normally Closed (N.C.)** contact.

See next page for details on how to navigate through LCD display menu to program desired function on AUX INPUT 1 & 2.

Connect device relay contacts to these two terminals. Relay COMMON to board COMMON.
RELAY N.O., N.C. or 10K to AUX INPUT 1. The relay contact depends on the function. See above for contact options.

Connect device relay contacts to these two terminals. Relay COMMON to board COMMON.
RELAY N.O., N.C. or 10K to AUX INPUT 2. The relay contact depends on the function. See above for contact options.

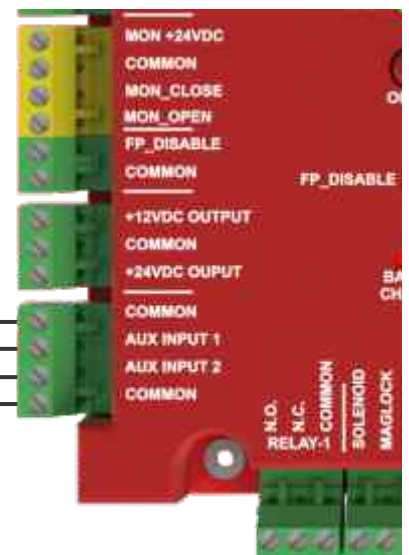

MAGNA Q LCD Display Menu Instructions

This guide walks you through navigating and configuring the MAGNA Q board using the built-in LCD display.

Getting Started: Waking Up the Display

1. Press the **OK** button repeatedly until you see the language options: <ENG and ESP>.
2. Select your language:
 - o Press **Left** (<) for **English**
 - o Press **Right** (>) for **Spanish**
3. After selecting a language, scroll to **SETTINGS** or **DIAGNOSTICS** and press **OK** to enter.

Navigation Controls:

- **Up/Down:** Scroll through menu items.
- **Left/Right:** Move cursor within fields.
- **OK:** Select or save an option.

SETTINGS MENU

1. Time & Date

- **Time (XX:XX AM)**
 1. Press **OK** with the cursor on TIME.
 2. Use **Left/Right** to move between hours, minutes, and AM/PM.
 3. Use **Up/Down** to adjust values.
 4. Press **OK** to save.
- **Date (MM/DD/YYYY)**
 1. Press **OK** with the cursor on DATE.
 2. Use **Left/Right** to move between month, day, and year.
 3. Adjust with **Up/Down** buttons.
 4. Press **OK** to save.

2. Power Settings

- **Current Sense PRGV**
 - o Adjusts how responsive the ERD (Electronic Reversing Device) is.
 - o **Options:** Progressive (less sensitive), Threshold (more sensitive).
- **ERD (Electronic Reversing Device)**
 - o **Open ERD:** Adjust opening force.
 - o **Close ERD:** Adjust closing force. These can also be accessed via quick-access **OPEN/CLOSE ERD** buttons.

3. 7-Day Timer

- **Events 1–10**

1. Each event can control:
 - OPEN, CLOSE, AUX RELAY ONE, AUX RELAY TWO
 2. For each event, set:
 - **Start Time (activate)**
 - **End Time (deactivate)**
 - **Days of Operation**
 - Scroll through the days and
 - Use **Right** button to toggle days ON/OFF
 - Once desired days have been turn ON press OK button.
- Make sure the system **Time & Date** is set correctly for the timer to work.

NOTE: A hard CLOSE command will override an OPEN event.

4. Leaf Delay

- Set delay for either **Open** or **Close**
- Use **Up/Down** to adjust seconds (00.0 SEC)

5. Arming Loop (Phantom Loop)

- Toggle the **Arming Loop** ON or OFF
 - o Use the UP button to toggle ON/OFF
- **NOTE:** this is used when an arming loop is required for access control devices

6. Pre-Warn Alarm (Uses integrated alarm)

- Audible alert during arm movement.
 - o Toggle **ON/OFF**
 - o Set **Delay** (0–12 seconds)
 - o Press OK once done to save

7. AMS Mode (ON/OFF)

- **AMS (Access Management System)** mode is to manage the access opening sequence of a gate and barrier arm operator combination
 - o To Enable/Disable Toggle **ON/OFF**
 - o Aux Relay 1 will be used to send an open command to a gate operator
 - o Aux Input 1 will be used to receive the gate gate operator open limit signal

8. Auxiliary Relays

AUX Relay One & Two Options:

LCD SETTINGS AND DIAGNOSTICS (CONT.)

1. **OFF (Inactive)**
2. **GATE OPEN CMD** (*Relay One only*) – Indicates arm not fully lowered.
3. **LSI Signal** (*Relay Two only*) – Toggles red/green LED strip based on arm motion.
4. **MOVING SIGNAL** – Relay activates during movement.
5. **OPENED SIGNAL** – Activates when arm fully raised.
6. **CLOSED SIGNAL** – Activates when arm fully lowered.

9. Auxiliary Inputs

- **Inputs 1 and 2 Functions:**
 - EMERGENCY OPEN / CLOSE
 - OPEN CMD
 - CLOSE CMD
 - MON-OPEN
 - MON-CLOSE
 - STOP CMD
 - GATE OPEN LIMIT (AMS MODE)

10. Service Cycle (used to program a service call)

- Program cycle count for preventative maintenance.
 - Set total cycles required
 - Board will beep when service is due
 - Reset counter via **Diagnostics > Cycle Count**

11. Auto-Close Timer

- Can also be accessed via quick-access **TIMER** button
- Set delay (0–120 seconds)

12. Settings Change Log

- Stores last 3 most recent setting changes
- Displays **Date & Time** of change

13. Update Firmware

- Use a **USB Thumb Drive** (must be formatted FAT/FAT16/FAT32)
- With BIN file provided by AOM
- Insert into USB port to update firmware
- Once Thumb Drive is recognized, a prompt will appear
 - Press OK button to start the update

14. Wireless Setup (used to change wireless channels)

- Set wireless channel (1–8)
- Switch channels if other operators are operating nearby
- Ensure primary/secondary units use the **same channel**

15. Set to Default

- Options to reset:
 - DEFAULT ALL
 - Or individual sections (e.g., Power, Timer, Relays, etc.)

DIAGNOSTICS MENU

1. Barrier Status

- Displays whether arm is OPEN, CLOSED, or STOPPED

2. Communication

- Shows connection type: WIRED or WIRELESS

3. 7-Day Timer Status

- Current action status (e.g., KEPT OPEN)
- AUX RELAY 1 and 2 ON/OFF status

4. Voltage Meter

- **Battery Voltage**
- **Line-In Voltage**

5. Motor Diagnostics

- **Motor Speed**
- **Gate Travel** (% open)

6. Last Event

- Last recorded event with **date & time stamp**

7. Event Log

- Stores up to **50 logged events with date & time stamp**

8. Cycle Count

- Displays:
 - **Life Cycles**
 - **Monthly / Daily Cycles**
 - **Service Cycles** (Includes reset option)

9. Export to USB

- Export diagnostic data to USB
- Plug-in a USB thumb drive (must be formatted FAT/FAT16/FAT32)
- Once Thumb Drive is recognized, a prompt will appear
 - Press OK to proceed to export
- Viewable on smartphone or PC

MAGNA Q MANUAL RELEASE

Procedure to Manually Raise or Lower the Arm:

1. Unplug the motor power harness from the board.
2. Pull out the blue spindle handle on the motor.
3. Turn the spindle to manually raise or lower the arm.
4. Once the arm is in the desired position, fold the spindle handle back in.
5. Reconnect the motor power harness to the board.

SAFETY TIPS:

1. It's important to disconnect the motor power harness from the board. As it prevents the motor from spinning unintentionally.
2. Also, disconnecting the motor from the board it will be easier to turn the spindle.

MANUAL OPERATION TIPS:

If possible to reach the arm as the spindle is being turned, the arm can move by grabbing it and forcing it in the desired direction. The arm will lock in place in the fully raised or lowered position.

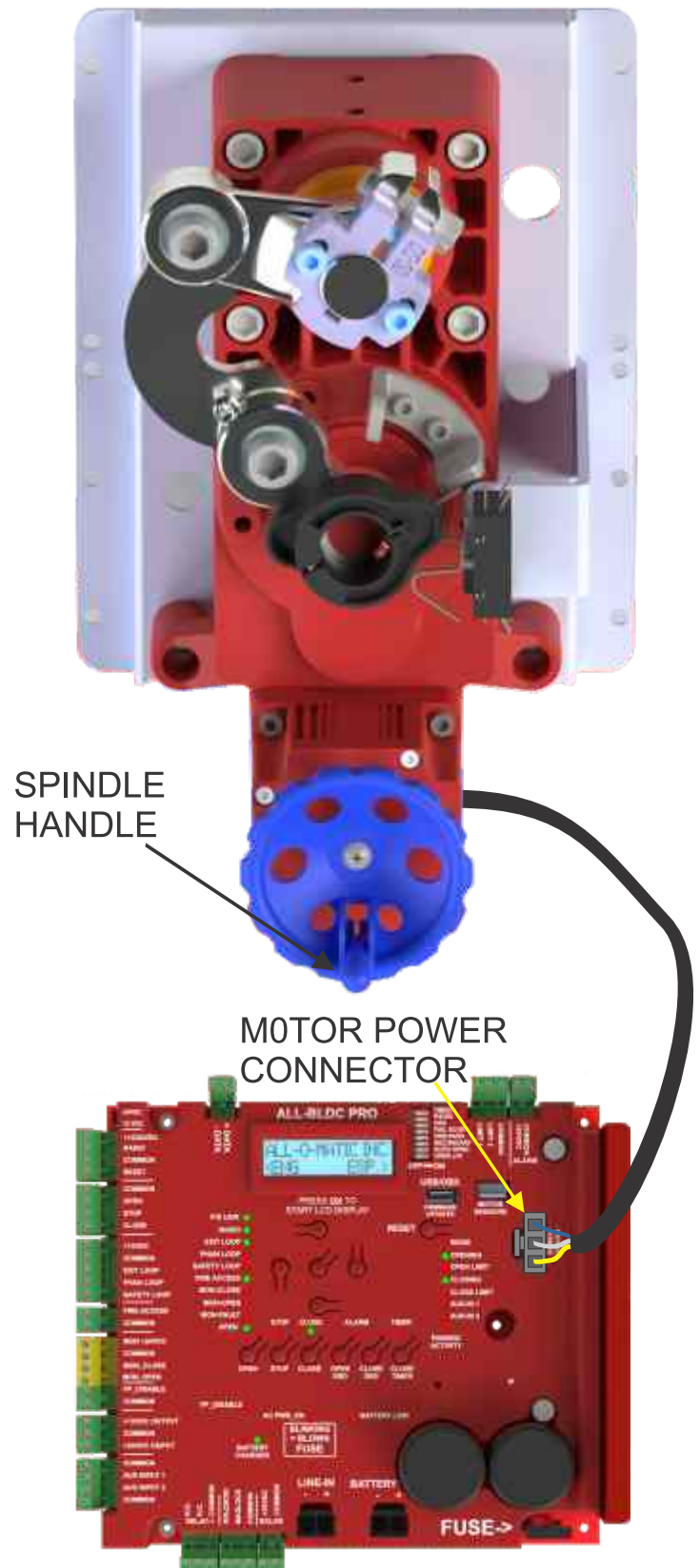

WARRANTY CARD

MANUFACTURER'S LIMITED WARRANTY

ALL-O-MATIC INC warrants the MAGNA Q aluminum cabinet for a period of ten (10) years and electrical & mechanical components for a period of three (3) years. The above operator, within its warranty period, is to be free from defects in circuitry, motor, gearbox and workmanship. This warranty begins from the date of purchase to the original owner. Warrantor will repair or, at its option, replace any device which it finds to require service. This device must be sent to the warrantor at the consumer's expense to:

**ALL-O-MATIC INC.
7658 HASKELL AVE.
VAN NUYS, CA 91406**

The warrantor will return the repaired or replaced unit to the customer at the consumer's expense. Labor charges for dealer service or replacement are the responsibility of the owner. These warranties are in lieu of all other warranties either expressed or implied, and ALL-O-MATIC INC shall not be liable for consequential damage. All implied warranties of merchantability and or fitness for a particular purpose are hereby disclaimed and excluded. This limitation is not valid in jurisdictions which do not allow limitation of incidental or consequential damages or limitation of warranty periods. In order to obtain this policy, please complete the registration card and send it by mail within 30 days of purchasing from ALL-O-MATIC INC. or your installer. If product is not registered, only a one year warranty on all parts will be provided.

CUT HERE

OWNERS REGISTRATION CARD (Owner of property where gate operator is installed)

Customers Name _____ Phone _____

Address _____ City _____

State _____ Zip _____ E-MAIL: _____

Purchased from (Installation Co.) _____ Date _____

Address _____ City _____ State _____ Zip _____

Phone _____ E-MAIL: _____

Model Number _____ Serial Number _____ - _____

PLEASE RETURN THIS PORTION

ALL-O-MATIC GATE OPERATORS

WARRANTY CARD

This card must be mailed and filed for warranty to be valid

(Please retain this portion)

CUSTOMERS RECORD

Customer Name _____

Address _____

Purchased from (Installation Co.) _____ Date _____

Model Number _____ Serial Number _____ - _____

Please retain this portion as a receipt for warranty for your own protection

CUT HERE

PLACE
STAMP
HERE

**ALL-O-MATIC INC.
7658 HASKELL AVE.
VAN NUYS, CA 91406**



Power Door Products

(914) 698-5083

www.PowerDoorProducts.com

ALL-O-MATIC[®]

MANUAL



UL 325 & UL991
COMPLIANT

CANADA
ESA C22.2
COMPLIANT